

REVISIONS			
REV.	DESCRIPTION	DATE	ECN
A	INITIAL RELEASE	5/12/09	1182

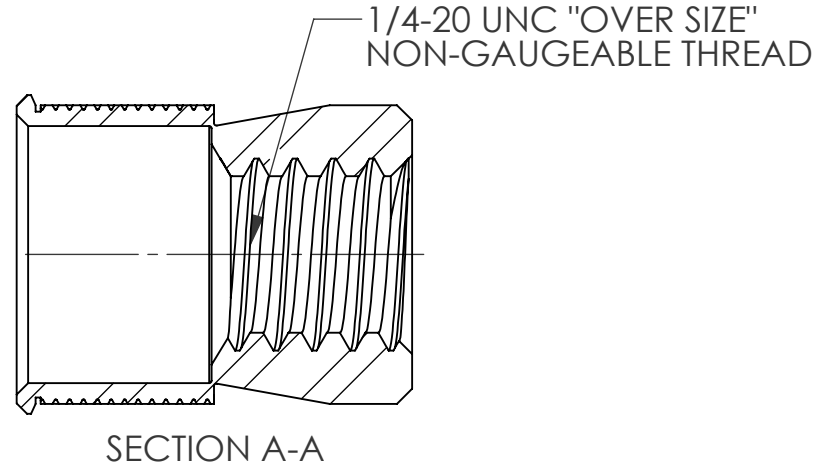
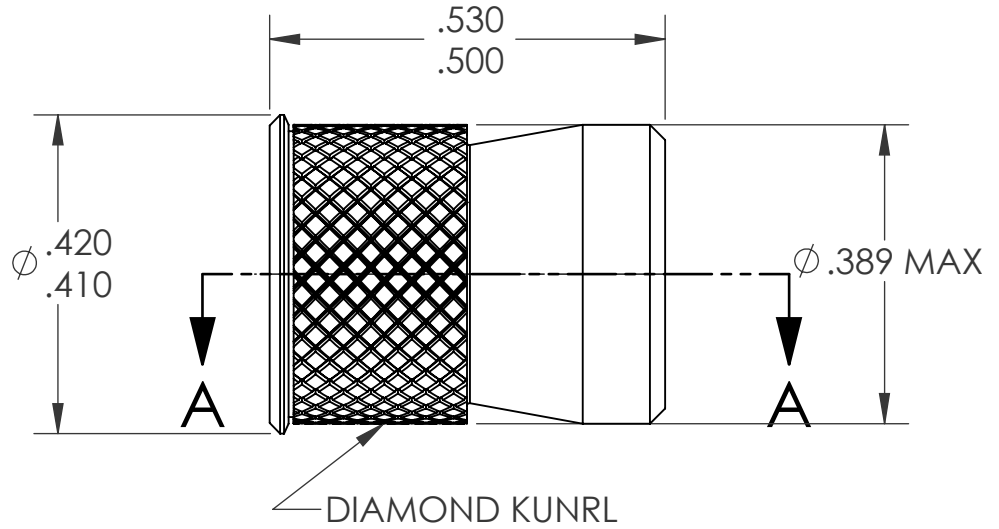
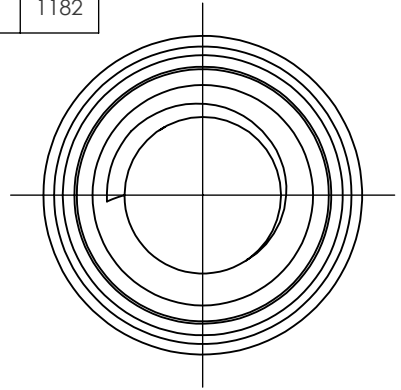
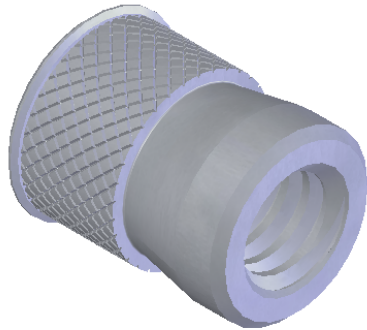

NOTE:

- GRIP RANGE: .062 MIN.
- HOLE SIZE: .391 +.005/-.000 AFTER ALL APPLIED FINISHES.
- INSTALLED LENGTH: N/A
- LUBRICATION: NONE
- INSTALLATION TOOL: SSG 802 SPIN SPIN

PROPRIETARY AND CONFIDENTIAL
 THIS DRAWING, AND THE INFORMATION CONTAINED HEREIN, ARE THE PROPERTY OF SHEREX AND ARE NOT TO BE USED IN ANY MANNER DETRIMENTAL TO THE INTEREST OF THE COMPANY.
 SHEREX SOLUTIONS RESERVES THE RIGHT TO REVISE PART/DRAWING WITHOUT NOTICE.

		UNLESS OTHERWISE SPECIFIED:		NAME	DATE	
		DIMENSIONS ARE IN INCHES TOLERANCES: ANGULAR: MACH ±1 BEND ±1 TWO PLACE DECIMAL ±.01 THREE PLACE DECIMAL ±.002		DRAWN	TWR 5/12/09	
		INTERPRET GEOMETRIC TOLERANCING PER: ASME Y14.5M-1994		CHECKED		
		MATERIAL		ENG APPR.	JVK 5/12/09	
		6061-T6 ALUMINUM		MFG APPR.		
		FINISH		Q.A.	JVK 5/12/09	TITLE: CADMIUM FREE KNURLED BODY SWAGING
NEXT ASSY	USED ON	TIN ALLOY PER PER ASTM B545		COMMENTS:		
APPLICATION		DO NOT SCALE DRAWING		E-mail: info@sherex.com www.sherex.com Phone: 866-474-3739 Fax: 716-875-0358		
				SIZE DWG. NO.	REV	
				A CFW3-2520	A	
				SCALE: 2:1	WEIGHT: .0033 kg	SHEET 1 OF 1