

REVISIONS			
REV.	DESCRIPTION	DATE	ECN
A	INITIAL RELEASE	8/1/13	1612

HEAD STAMP

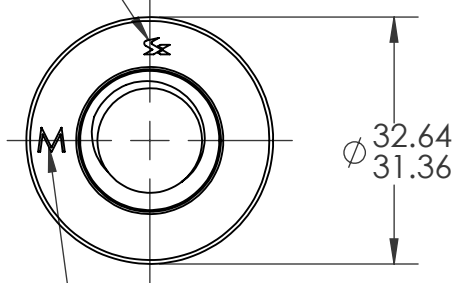

METRIC THREAD IDENTIFIER

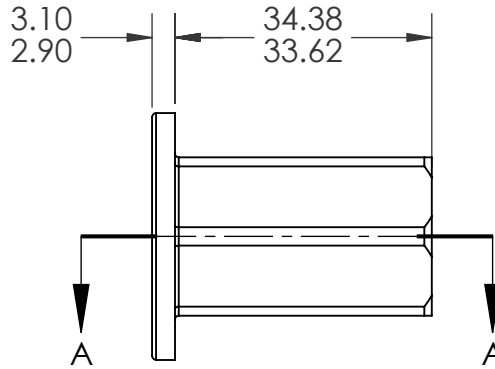

SECTION A-A

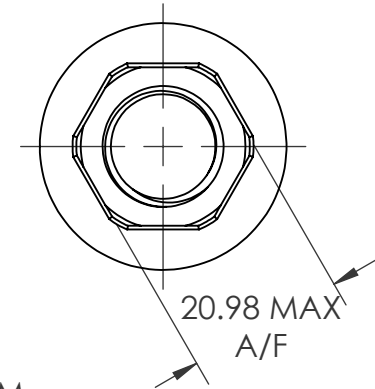

M16X2.0 6H  
PER ASME B1.13M  
MINOR DIA.: 13.84 - 14.21



NOTE:

- GRIP RANGE: 2.0 - 5.0
- HOLE SIZE: 21.0 +.25/-0.00 A/F AFTER ALL APPLIED FINISHES.
- INSTALLED LENGTH: 24.5 REF.
- LUBRICATION: NONE
- INSTALLATION TOOL: FLEX 18 SPIN PULL

**PROPRIETARY AND CONFIDENTIAL**

THIS DRAWING, AND THE INFORMATION CONTAINED HEREIN, ARE THE PROPERTY OF SHEREX AND ARE NOT TO BE USED IN ANY MANNER DETRIMENTAL TO THE INTEREST OF THE COMPANY.  
SHEREX SOLUTIONS RESERVES THE RIGHT TO REVISE PART/DRAWING WITHOUT NOTICE.

		UNLESS OTHERWISE SPECIFIED:	NAME	DATE
		DIMENSIONS ARE IN MILLIMETERS TOLERANCES: ANGULAR: MACH ± 1 BEND ± 1 ONE PLACE DECIMAL ± 0.10 TWO PLACE DECIMAL ± 0.05	DRAWN	CL 8/1/13
		INTERPRET GEOMETRIC TOLERANCING PER: ASME Y14.5M-1994	CHECKED	
		MATERIAL	ENG APPR.	JVK 8/1/13
		C1010/C1022	MFG APPR.	
		FINISH	Q.A.	JVK 8/1/13
		ZINC PLATE CLEAR TRIVALENT CHROMATE PER SHEREX SFS-01-001	COMMENTS:	
NEXT ASSY	USED ON		E-mail: info@sherex.com	
			www.sherex.com	
			Phone: 866-474-3739	
			Fax: 716-875-0358	
	APPLICATION	DO NOT SCALE DRAWING		



TITLE:  
LARGE THREAD FULL HEX

SIZE DWG. NO. REV  
**A** LRGH2-1620-5.0 A

SCALE: 2:1 WEIGHT: SHEET 1 OF 1