



**SHEREX FASTENING SOLUTIONS
PNEUMATIC SPIN-SPIN PISTOL STYLE
RIVET NUT INSTALLATION TOOL**

**SSG-801 / 802
MANUAL**



**SSG-801
Specifications**

R.P.M. - 3000
***Air pressure** - 35-90 psi (oiled)
Weight - 3.0 lbs. (1.4 kg)
Air inlet - 1/4"
Air consumption - 5 CFM
Hose Diameter - 3/8"
Thread Size - Unified: 4-40, 6-32, & 8-32
Metric: M3 & M4

**SSG-802
Specifications**

R.P.M. - 1500
***Air pressure** - 60-90 psi (oiled)
Weight - 3.0 lbs. (1.4 kg)
Air inlet - 1/4"
Air consumption - 5 CFM
Hose Diameter - 3/8"
Thread Size - Unified: 10-24, 10-32, 1/4-20, & 1/4-28
Metric: M5 & M6

*Must be adjusted to suit thread size/application

HEAD SET ASSEMBLY DIRECTIONS

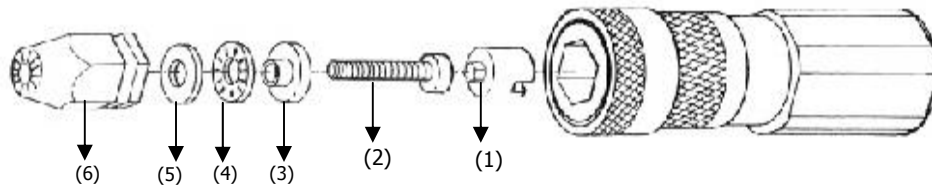

(1.) Assemble the bearing set & mandrel (parts 2,3,4,5) shown in the figure above.

(2.)



(2.) Insert part 1 into the Gun Body. Rotate part 1 until the slot connects with the Gun Body, shown in the figure to the left.

(3.)

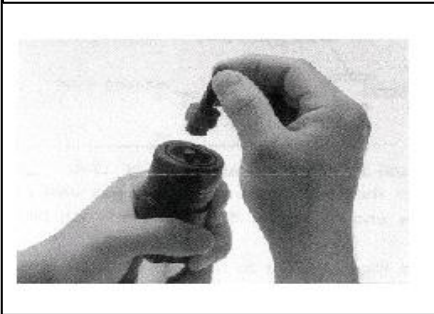

(3.) Install the pre-assembled bearing set with part 1.

(4.)



(4.) Insert part 6 into Gun Body's hexagon slot.

(5.)



(5.) Push Gun Body's quick releasing ring backward and push part 6 into the Gun Body. Completely release the quick releasing ring to complete the tool assembly.

Sherex Spin/Spin Pistol Style Rivet Nut Tool

SSG-801/802 Dimensions



Instructions for Use:

1. Insert head set into tool as described on page 2.
2. Turn the rivet nut onto the cap screw — 1 complete turn.
3. Insert the rivet nut into the work piece.
4. Depress the top part of the trigger (F position). When the rivet nut is completely installed the tool will stall.
5. Once the tool stalls, release the top part of the trigger (F position) and depress the bottom of the Trigger (R position). The tool will reverse out of the work piece leaving the rivet nut completely installed.

The SSG 800 Series provides a quick and easy way of installing rivet nuts. This tool uses torque to install rivet nuts so it does not need any adjustment, it is already set for the rivet nut. **If necessary, minor adjustments can be made by increasing or decreasing air pressure.**

This tool is recommended for use with Sherex CAL, CAK, CAH, CAO, CPB, CFT/CAT, and CFW/CAW rivet nuts. Feel free to contact Sherex about special applications, or use with other rivet nut styles not listed above.

**Sherex Fastening Solutions, LLC ~ 400 Riverwalk Pkwy, Suite 600 Tonawanda, NY, 14150
866-4SHEREX ~ www.sherex.com**

SSG TOOL MAINTENANCE

BEARING ASSEMBLY – It is important that the thrust bearing be lubricated with SSG-LUBE available thru *Sherex*. The bearing assembly and mandrel (socket head cap screws) are located in the nose piece of the tool. Lubricate as needed, bearing should not run dry. Remove the nose piece & proceed as follows:

- 1) Remove the bearing & socket head cap screw.
- 2) Separate the bearing from the races & lubricate. Work grease into bearing. **Replace socket head cap screw if worn or damaged.** Use only high quality grade 8/Class 12.9 socket head cap screws, part number are listed on page 27 of the *Sherex* catalog.
- 3) Reassemble.

PREVENTATIVE MAINTENANCE –

- 1) **LUBRICATE MANDREL.** In some applications it may be advisable to dip the first one or two threads of the mandrel into a light oil after several installations to minimize wear.
- 2) **HANDLE WITH ORDINARY CARE.** A large number of tool repairs can be traced to improper handling. In spite of their durable appearance, air tools should not be used as hammers or pry bars, nor should they be deliberately dropped or dragged along the floor.
- 3) **IF LINE OILER** is not used, apply a small amount of Spindle Oil in the air inlet of the tool and run free for one minute to insure proper lubrication; repeat after 8 hours of operation.

CAUTION: An excessive amount of lubricant in a tool will affect the speed and power. Each set of planetary gearing should contain approximately ½ ounce of grease.

FAILURE TO FOLLOW ROUTINE MAINTNANCE DESCRIBED COULD VOID WARRANTY

AIR PRESSURE TROUBLE-SHOOTING: CHECKING SUPPLY AND FITTINGS

If recommended pressures cannot be obtained, the supply system should be checked. Some things to look for are:

- 1) Inadequate compressor capacity.
- 2) Improper pipe sizes (I.D. too restrictive).
- 3) Restrictions caused by fittings with I.D.'s too small. See note above.
- 4) Be sure hose and quick disconnect fittings have 5/16" I.D.
- 5) Shut-off valves. It is best to use stop cock type, which lessens restrictions.
- 6) Improper coupler and quick disconnect. Use only those with good flow characteristics and assure that they mate correctly.
- 7) Filter-regulator-lubricator should be compatible, properly sized and maintained.
- 8) Clogged filter.

SSG TOOL TROUBLESHOOTING

Below are some guidelines for solutions to common setting and tooling problems. By following these steps you should be able to get back into production as quickly as possible if a problem arises:

1) SCREWS BREAK FREQUENTLY –

- a) Too much air line pressure. Check the air pressure specs for the thread size you are placing. Adjust downward accordingly.
- b) Make sure operator is holding the tool at a 90 degree angle to the work piece, and not tilting it over to one side.

2) TOOL STALLS BEFORE FULLY PLACING THE INSERT –

- a) Be sure there is a bearing assembly in the tool. Check to be sure it is not worn out, and that it is assembled correctly. Clean in solvent, blow dry and lubricate with recommended grease.
- b) Check for quick disconnect fittings with holes of 1/4" or 3/16". These may be too small to allow the necessary volume into the tool. This is especially critical with the 5/16, 3/8 and 1/2" thread sizes.
- c) Be sure hose I.D. is 5/16".
- d) Not enough air line pressure. Check the air pressure specs for the thread size you are installing. Adjust upward accordingly. To prevent against unfavorable drops in air pressure, regulated pressure readings should be measured at or near (within 30 feet) of the tool. This air pressure should be within the recommended range of the tool.
- e) Check the condition of the mandrel. Replace, if worn using high quality socket head cap screws.
- f) Check to see if other air tools are being used that are starving the insert installation tool.

3) TOOL WILL NOT START/RUN –

- a) With air system connected, quickly change from forward to reverse several times.
- b) Check your air line and air pressure to assure there is an adequate supply of air to the tool.
- c) Remove the complete tool nosepiece. Manually rotate the square drive shaft. Connect air to tool and depress trigger.
- d) Evaluate airline set-up portion.
- e) If there is an air motor failure, call *Sherex Customer Service*.

4) AIR MOTOR RUNS, MANDREL DOESN'T TURN -

- a) Make sure hex drive is engaged into the mandrel. Check to see if screw is broken or if the head is rounded out. Check also, if the hex drive itself has been rounded off. Replace defective parts as may be required to assure proper installation.

CALL *SHEREX CUSTOMER SERVICE* IF THESE PROCEDURES FAIL TO PROPERLY SET THE RIVET NUT.

SSG-801/802 PARTS BREAKDOWN

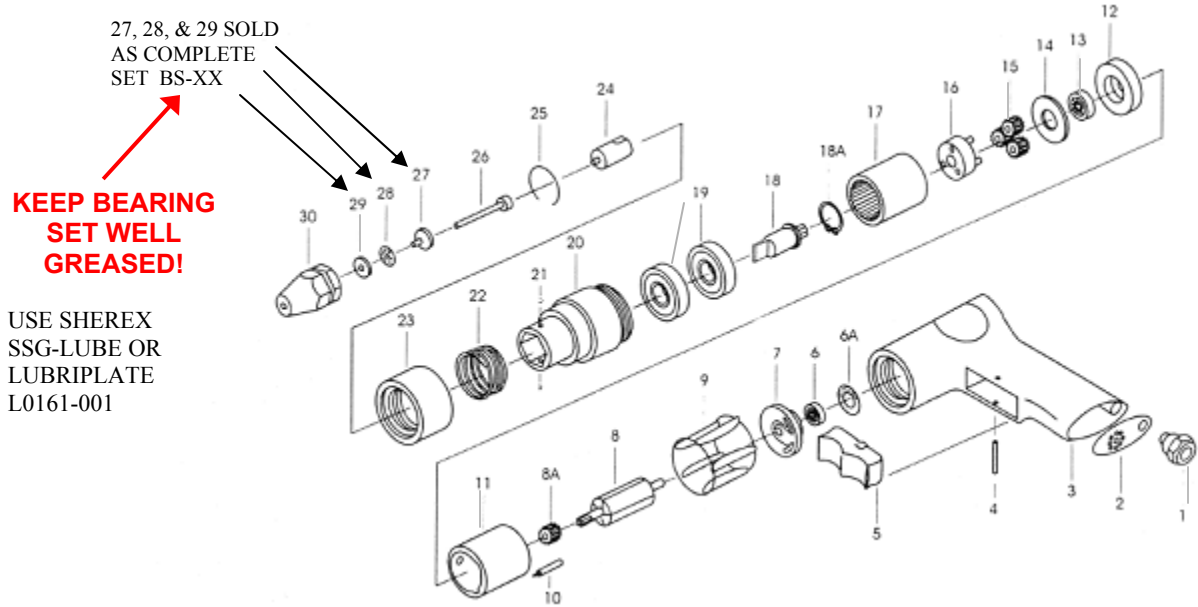

(Ref) Sherex Part No.	Description	No. Required	(Ref) Sherex Part No.	Description	No. Required
(1) SSG-802-1	Air Inlet	1	(16) SSG-801-16	Gear Cage	1
(2) SSG-802-2	Diffuser-Exhaust	1	(16) SSG-802-16	Gear Cage	1
(3) SSG-802-3	Handle Assembly	1	(17) SSG-802-17	Internal Gear	1
(4) SSG-802-4	Pin (3x28)	1	(18) SSG-802-18	Drive Spindle	1
(5) SSG-802-5	Trigger	1	(18A) SSG-802-18A	Retaining Ring	1
(6A) SSG-802-6A	Gasket	1	(19) SSG-802-19	Ball Bearing (6200z)	2
(6) SSG-802-6	Ball Bearing (696zz)	1	(20) SSG-802-20	Nose Housing	1
(7) SSG-802-7	Rear Plate	1	(21) SSG-802-21	Locking Balls	2
(8) SSG-802-8	Rotor (6T)	1	(22) SSG-802-22	Change Value Spring	1
(8A) SSG-801-8A	Sun Gear (12T)	1	(23) SSG-802-23	Quick Change Sleeve	1
(9) SSG-802-9	Rotor Blade	5	(24) HD-XX	Hex Driver	1
(10) SSG-802-10	Roll Pin (2.5x10)	2	(25) SSG-802-25	Circlip	1
(11) SSG-802-11	Cylinder	1	(26) M-XXXX-XXX	Mandrel (socket head cap screw)*	1
(12) SSG-802-12	Front End Plate	1	(27, 28, & 29)		1ea
(13) SSG-802-13	Ball Bearing (626zz)	1	Sold as a set BS-4 to BS-25 BS-M3 to BS-M6	Rear Thrust Plate, Roller Bearings & Washer (Bearing Set)	
(14) SSG-802-14	Washer	1			
(15) SSG-801-15	Planet Gear (15T)	3	(30) Nose Piece	Nose Piece (Sold w/Head sets) Head Sets Designated by Thread Size.	1
(16) SSG-802-15	Planet Gear (18T)	3		801: HS-0440, HS-0632, HS-0832, HS-M3, HS-M4. 802: HS-1024, HS-1032, HS-2520, HS-2528, HS-M5, HS M6.	
Head Sets Include 24, 26, 27, 28, 29, & 30					

*Use only high quality Socket Head Cap Screws such as Unbrako®, or Holokrome®