

REVISIONS			
REV.	DESCRIPTION	DATE	ECN
A	INITIAL RELEASE	12/15/10	1378

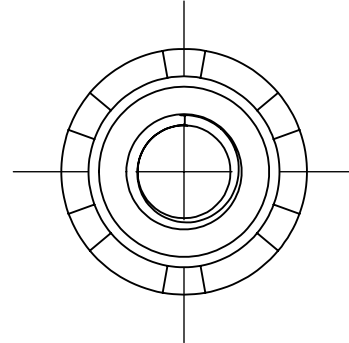

M6X1.0 6H
PER ASME B1.13M
4.92 - 5.15

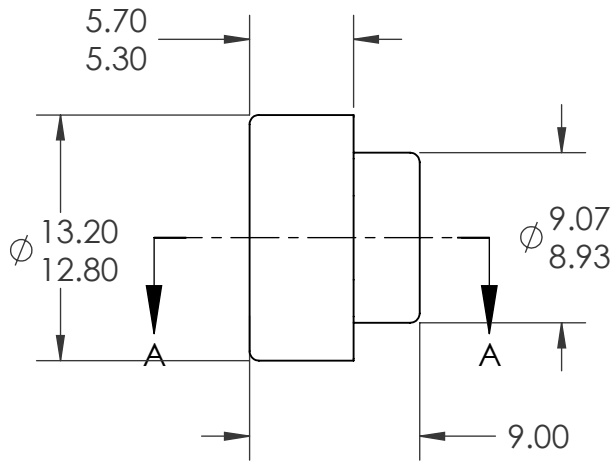

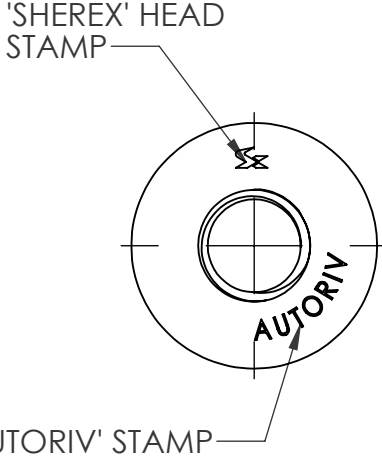
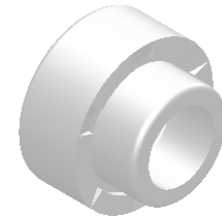
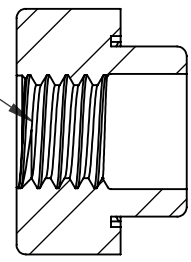

SECTION A-A
SCALE 2.5 : 1

NOTE:
1. SHEET THICKNESS: 0.4 - 6.0
2. HOLE SIZE: 9.20 +.00/-.10 AFTER ALL APPLIED FINISHES

PROPRIETARY AND CONFIDENTIAL
THIS DRAWING, AND THE INFORMATION CONTAINED HEREIN, ARE THE PROPERTY OF SHEREX AND ARE NOT TO BE USED IN ANY MANNER DETRIMENTAL TO THE INTEREST OF THE COMPANY.
SHEREX SOLUTIONS RESERVES THE RIGHT TO REVISE PART/DRAWING WITHOUT NOTICE.

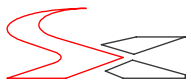
		UNLESS OTHERWISE SPECIFIED:	NAME	DATE
		DIMENSIONS ARE IN MILLIMETERS TOLERANCES: ANGULAR: MACH ± 1 BEND ± 1 ONE PLACE DECIMAL ± 0.10 TWO PLACE DECIMAL ± 0.05	DRAWN	CL 11/29/10
		INTERPRET GEOMETRIC TOLERANCING PER: ASME Y14.5M-1994	CHECKED	
		MATERIAL	ENG APPR.	JVK 11/29/10
		C1035/C1040	MFG APPR.	
		FINISH	Q.A.	JVK 11/29/10
		PLAIN ZINC, 3um MIN.	COMMENTS:	
NEXT ASSY	USED ON		E-mail: info@sherex.com www.sherex.com Phone: 866-474-3739 Fax: 716-875-0358	
APPLICATION		DO NOT SCALE DRAWING		

TITLE:
ARN CLINCH NUT

SIZE DWG. NO.	REV
A ARN2-610-6.0	A

SCALE: 2:1 WEIGHT: SHEET 1 OF 1