

REVISIONS

REV.	DESCRIPTION	DATE	ECN
A	INITIAL RELEASE	12/15/10	1378

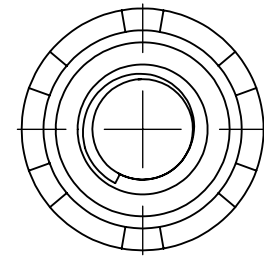

M8X1.25 6H
PER ASME B1.13M
MINOR DIA.: 6.65 - 6.91

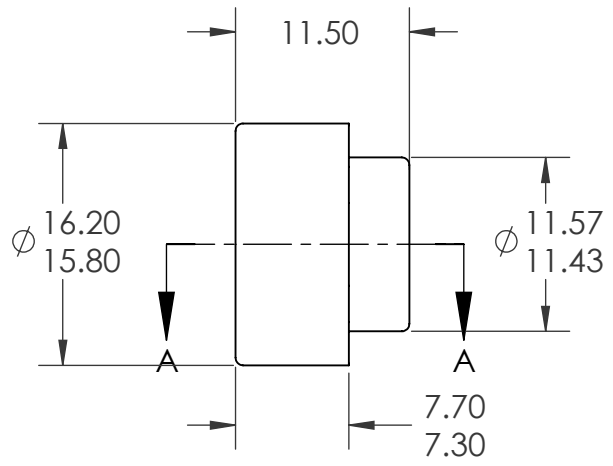
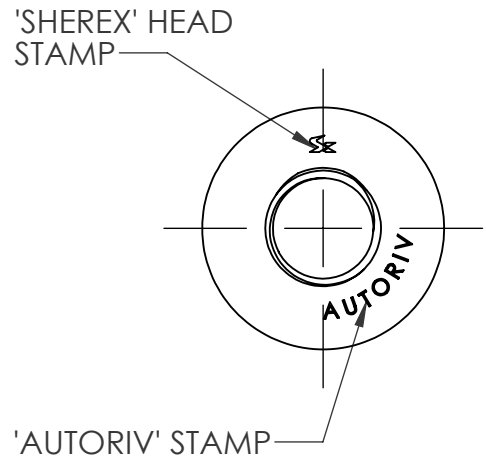
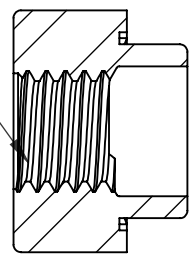

SECTION A-A
SCALE 2 : 1

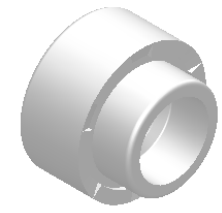

- NOTE:
1. SHEET THICKNESS: 0.4 - 6.0
 2. HOLE SIZE: 11.70 +.00/- .10 AFTER ALL APPLIED FINISHES

PROPRIETARY AND CONFIDENTIAL
THIS DRAWING, AND THE INFORMATION CONTAINED HEREIN, ARE THE PROPERTY OF SHEREX AND ARE NOT TO BE USED IN ANY MANNER DETRIMENTAL TO THE INTEREST OF THE COMPANY.
SHEREX SOLUTIONS RESERVES THE RIGHT TO REVISE PART/DRAWING WITHOUT NOTICE.

		UNLESS OTHERWISE SPECIFIED:	NAME	DATE
		DIMENSIONS ARE IN MILLIMETERS TOLERANCES: ANGULAR: MACH ± 1 BEND ± 1 ONE PLACE DECIMAL ± 0.10 TWO PLACE DECIMAL ± 0.05	DRAWN	CL 12/2/10
		INTERPRET GEOMETRIC TOLERANCING PER: ASME Y14.5M-1994	CHECKED	
		MATERIAL	ENG APPR.	JVK 12/2/10
		C1035/C1040	MFG APPR.	
		FINISH	Q.A.	JVK 12/2/10
		PLAIN ZINC, 3um MIN.	COMMENTS:	
NEXT ASSY	USED ON		E-mail: info@sherex.com	
			www.sherex.com	
			Phone: 866-474-3739	
			Fax: 716-875-0358	
APPLICATION		DO NOT SCALE DRAWING		



TITLE:
ARN CLINCH NUT

SIZE DWG. NO. REV
A ARN2-8125-6.0 A

SCALE: 2:1 WEIGHT: SHEET 1 OF 1