

REVISIONS			
REV.	DESCRIPTION	DATE	ECN
A	INITIAL RELEASE	12/31/08	1131

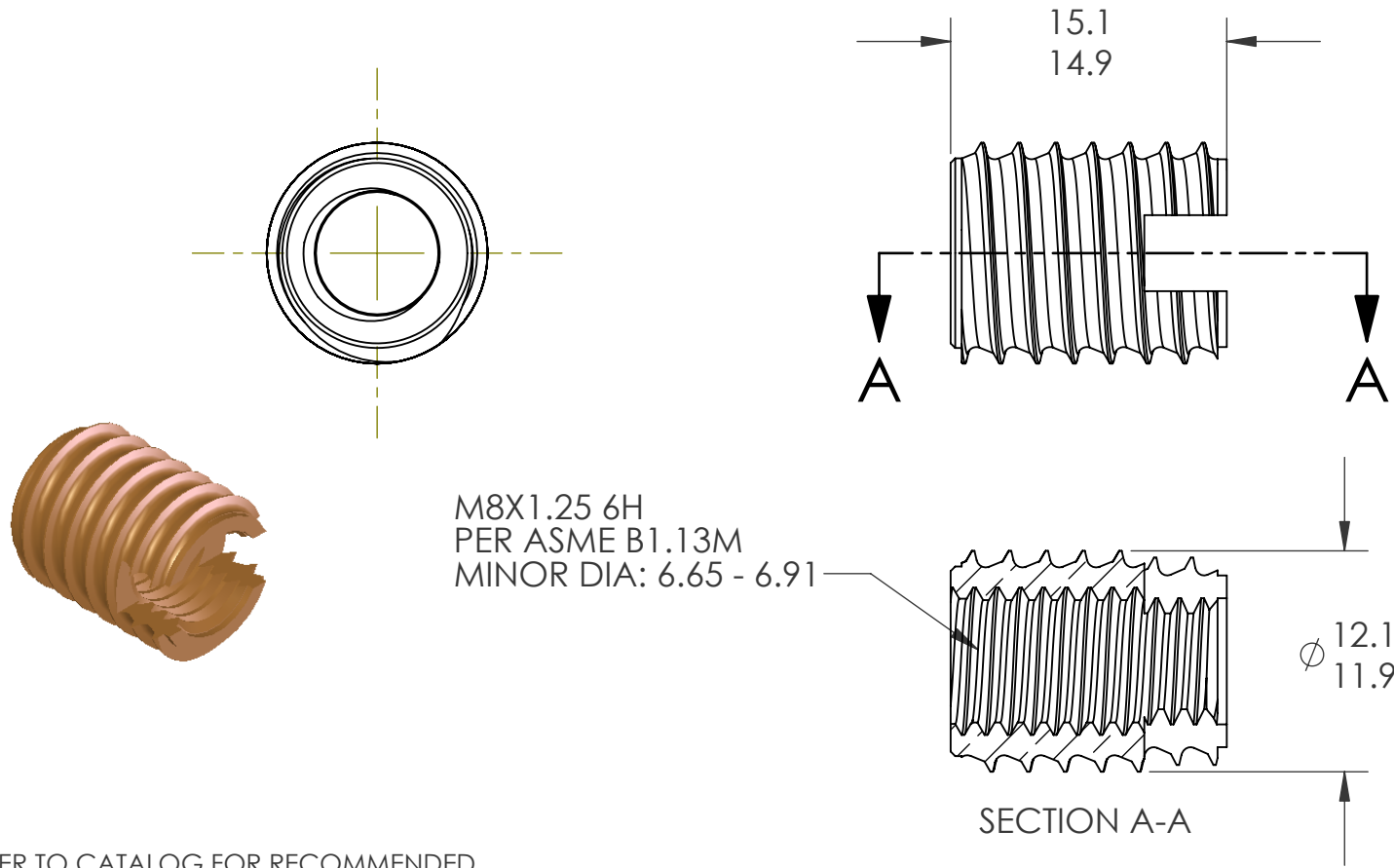

NOTES:

- REFER TO CATALOG FOR RECOMMENDED BOSS DIMENSIONS

PROPRIETARY AND CONFIDENTIAL
THIS DRAWING, AND THE INFORMATION CONTAINED HERIN, ARE THE PROPERTY OF SHEREX AND ARE NOT TO BE USED IN ANY MANNER DETRIMENT TO THE INTEREST OF THE COMPANY.
SHEREX RESERVES THE RIGHT TO REVISE PART/DRAWING WITHOUT NOTICE.

		UNLESS OTHERWISE SPECIFIED: DIMENSIONS ARE IN MILLIMETERS TOLERANCES: ANGULAR: MACH ±1 BEND ±1 ONE PLACE DECIMAL ±.2 TWO PLACE DECIMAL ±.10 INTERPRET GEOMETRIC TOLERANCING PER: ASME Y14.5M-1994		NAME	DATE
		MATERIAL BRASS C3604		JVK	12/9/08
		FINISH NONE		JVK	12/9/08
				TB	12/30/08
				COMMENTS: E-mail: info@sherex.com www.sherex.com Phone: 866-474-3739 Fax: 716-875-0358	
NEXT ASSY	USED ON				
APPLICATION		DO NOT SCALE DRAWING			



TITLE:
M8 THREADSERT

SIZE A	DWG. NO. B1T-8125-15.0	REV A
------------------	---------------------------	----------

SCALE: 2.5; WEIGHT: kg SHEET 1 OF 1