

REVISIONS			
REV.	DESCRIPTION	DATE	ECN
A	INITIAL RELEASE	12/31/08	1131

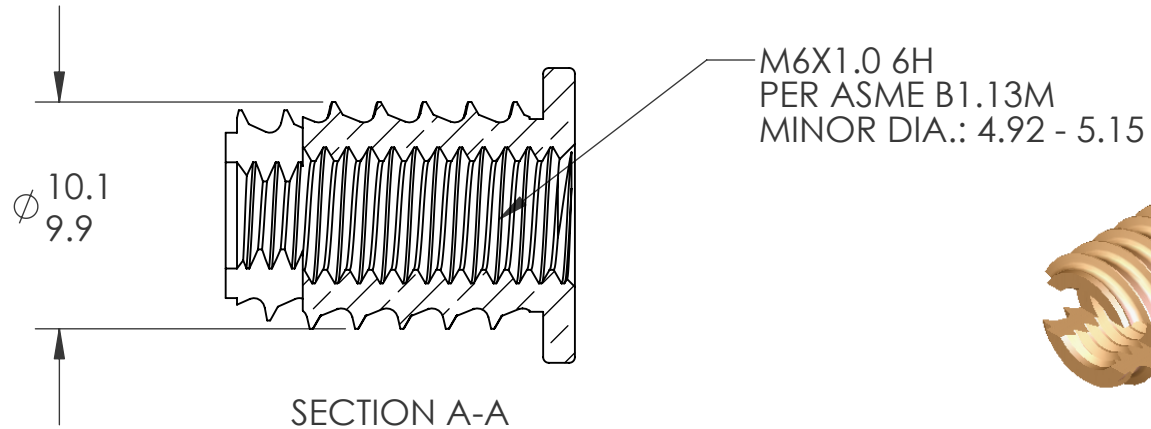
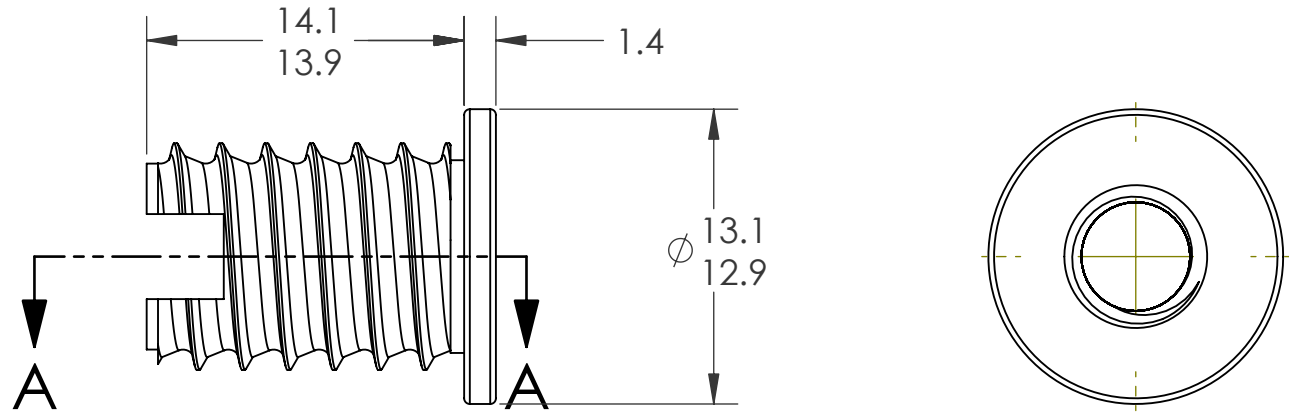

NOTES:

- REFER TO CATALOG FOR RECOMMENDED BOSS DIMENSIONS

**PROPRIETARY AND CONFIDENTIAL**  
 THIS DRAWING, AND THE INFORMATION CONTAINED HEREIN, ARE THE PROPERTY OF SHEREX AND ARE NOT TO BE USED IN ANY MANNER DETRIMENTAL TO THE INTEREST OF THE COMPANY.  
 SHEREX RESERVES THE RIGHT TO REVISE PART/DRAWING WITHOUT NOTICE.

		UNLESS OTHERWISE SPECIFIED: DIMENSIONS ARE IN MILLIMETERS TOLERANCES: ANGULAR: MACH ±1 BEND ±1 ONE PLACE DECIMAL ±.2 TWO PLACE DECIMAL ±.10 INTERPRET GEOMETRIC TOLERANCING PER: ASME Y14.5M-1994		NAME	DATE
				DRAWN	JVK 12/9/08
				CHECKED	
				ENG APPR.	JVK 12/9/08
				MFG APPR.	TB 12/30/08
				Q.A.	
		MATERIAL BRASS C3604		COMMENTS: E-mail: info@sherex.com www.sherex.com Phone: 866-474-3739 Fax: 716-875-0358	
NEXT ASSY		USED ON		FINISH NONE	
APPLICATION		DO NOT SCALE DRAWING			

 <b>TITLE:</b> M6 FLANGED THREADSERT			
			<b>SIZE</b> <b>A</b>
SCALE: 3:1	WEIGHT:	kg	SHEET 1 OF 1