

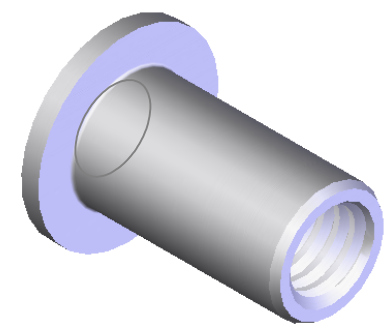

REVISIONS			
REV.	DESCRIPTION	DATE	ECN
A	INITIAL RELEASE	8/11/03	
B	UPDATE TO CURRENT FORMAT	6/3/10	1316
C	NEW FINISH PER SFS-01-001	1/23/15	1749

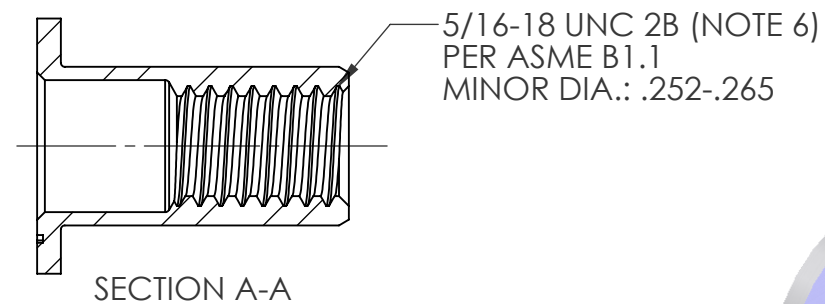

- NOTE:
- GRIP RANGE: .030 - .125
 - HOLE SIZE: .413 +.010/-.000 AFTER ALL APPLIED FINISHES.
 - INSTALLED LENGTH: .505 REF.
 - LUBRICATION: NONE
 - INSTALLATION TOOL: SPIN-PULL
 - MAY BE PRODUCED TO 3B THREAD CLASS DEPENDING ON THE MANUFACTURING LOT NUMBER OR CUSTOMER REQUIREMENT. SPECIFIC CLASS AVAILABLE UPON REQUEST.

PROPRIETARY AND CONFIDENTIAL
 THIS DRAWING, AND THE INFORMATION CONTAINED HERIN, ARE THE PROPERTY OF SHEREX AND ARE NOT TO BE USED IN ANY MANNER DETRIMENT TO THE INTEREST OF THE COMPANY.
 SHEREX RESERVES THE RIGHT TO REVISE PART/DRAWING WITHOUT NOTICE.

		UNLESS OTHERWISE SPECIFIED: DIMENSIONS ARE IN INCHES TOLERANCES: ANGULAR: MACH ±1 BEND ±1 TWO PLACE DECIMAL ±.01 THREE PLACE DECIMAL ±.005 INTERPRET GEOMETRIC TOLERANCING PER: ASME Y14.5M-1994 MATERIAL C1008/C1010/C1110 FINISH ZINC PLATE W/CLEAR TRIVALENT CHROMATE PER SFS-01-001		NAME JLA JLA AJP	DATE 8/11/03 8/11/03 8/11/03
NEXT ASSY	USED ON		COMMENTS: E-mail: info@sherex.com www.sherex.com Phone: 866-474-3739 Fax: 716-875-0358		
APPLICATION		DO NOT SCALE DRAWING			

 TITLE: FLAT HEAD OPEN END		
SIZE A	DWG. NO. CA-3118S-125	REV C
SCALE: 2:1	WEIGHT: .0077 kg	SHEET 1 OF 1