

Unified Thread (Unit - Inches)

Part Number (steel)	Thread Size	Grip Range		L	HD	HT	D	IL	HOLE SIZE
		Min.	Max.	±.015	±.010	±.003	Max.	Max.	+ .004 / - .000
CAH2-0632-080	6-32 UNC 2B	.020	.080	.385	.375	.027	.249	.295	.250

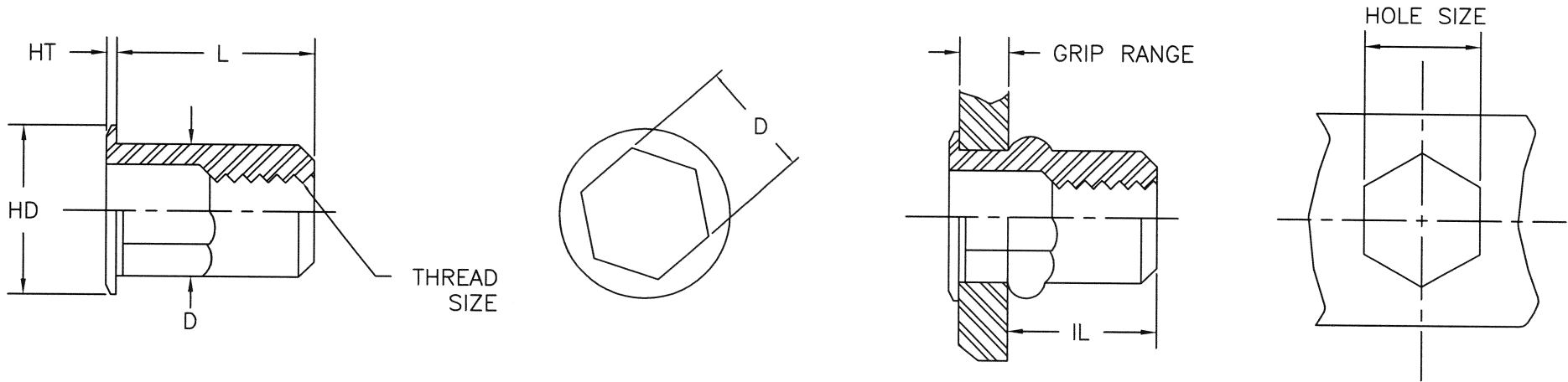

<b>CAH Specifications</b> Material: Steel 1008/1010 Stainless Steel 302 Aluminum 5056  Finish: Zinc Plated-Yellow Dichromate per ASTM B633 Fe/Zn 8, Type II		<b>Part Number Description</b> CAH2-0632-080  CAH 2 Product Style Material Semi Hex 1-Stainless Steel Thin Wall Series 2-Steel 3-Aluminum					0632 Thread Size	080 Grip Range	(-) Empty-Open End B-Closed End
---	--	--	--	--	--	--	---------------------	-------------------	---------------------------------------

THIS DRAWING, AND THE INFORMATION CONTAINED HERIN, ARE THE PROPERTY OF SHEREX FASTENING SOLUTIONS AND ARE NOT TO BE USED IN ANY MANNER DETRIMENTAL TO THE INTEREST OF THE COMPANY.

NOTE: SHEREX RESERVES THE RIGHT TO REVISE PART/DRAWING WITHOUT NOTICE.

SHEREX FASTENING SOLUTIONS

1400 COMMERCE PKWY.  
 LANCASTER, NY 14086 USA



SHEREX FASTENING SOLUTIONS

DRAWN BY: JLA	DATE: 8/11/03	SCALE: 1:1	TITLE: CAH STYLE RIVET NUT
------------------	------------------	---------------	-------------------------------

CHECK'D BY: JLA	DATE: 8/11/03	E-mail: info@sherex.com www.sherex.com  Phone: 866-474-3739 Fax: 716-681-0270
APPR'D BY: AJP	DATE: 8/11/03	

DRAWING NO.

CAH2-0632-080

REV	DESCRIPTION	ECN	DATE