

Metric Thread (Unit – Millimeters)

Part Number (steel)	Thread Size	Grip Range		L	HD	HT	D	IL	HOLE SIZE
		Min.	Max.	±.38	±.64	±.08	Max.	Max.	+ .10 / - .000
CAH2-1015-3.8	M10X1.5 ISO	0.70	3.80	17.40	16.64	0.89	12.70	13.46	12.70

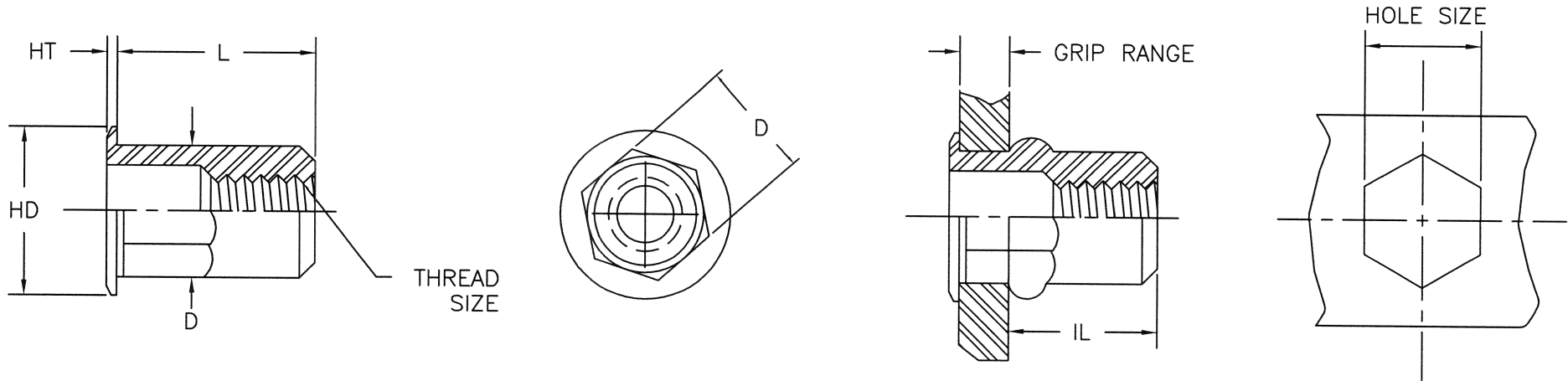

CAH Specifications Material: Steel 1008/1010 Stainless Steel 302 Aluminum 5056 Finish: Zinc Plated—Yellow Dichromate per ASTM B633 Fe/Zn 8, Type II		Part Number Description CAH2-1015-3.8 CAH Product Style Semi Hex Thin Wall Series					2 Material 1—Stainless Steel 2—Steel 3—Aluminum	1015 Thread Size	3.80 Grip Range	(-) Empty—Open End B—Closed End
---	--	---	--	--	--	--	---	---------------------	--------------------	---------------------------------------

THIS DRAWING, AND THE INFORMATION CONTAINED HERIN, ARE THE PROPERTY OF SHEREX FASTENING SOLUTIONS AND ARE NOT TO BE USED IN ANY MANNER DETRIMENTAL TO THE INTEREST OF THE COMPANY.

NOTE: SHEREX RESERVES THE RIGHT TO REVISE PART/DRAWING WITHOUT NOTICE.

SHEREX FASTENING SOLUTIONS
 1400 COMMERCE PKWY.
 LANCASTER, NY 14086 USA



REV	DESCRIPTION	ECN	DATE

DRAWN BY: JLA	DATE: 8/11/03	SCALE: 1:1	TITLE: CAH STYLE RIVET NUT
CHECK'D BY: JLA	DATE: 8/11/03	E-mail: info@sherex.com www.sherex.com	
APPR'D BY: AJP	DATE: 8/11/03	Phone: 866-474-3739 Fax: 716-681-0270	

DRAWING NO.
CAH2-1015-38