

REVISIONS			
REV.	DESCRIPTION	DATE	ECN
A	INITIAL RELEASE	8/11/03	
B	NEW FINISH PER SFS-01-001, SC2	1/21/15	1745

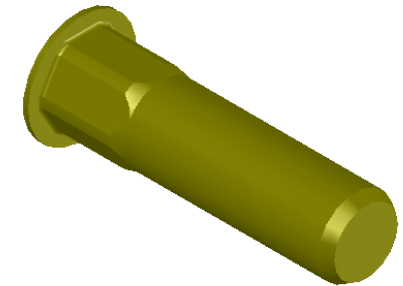
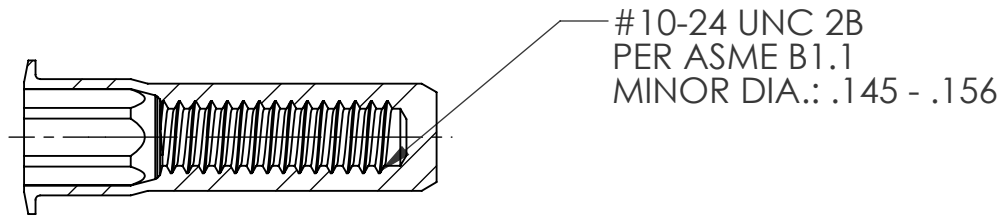
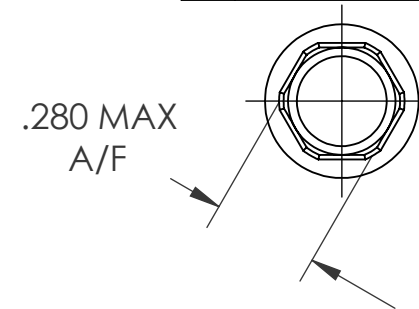

SECTION A-A
SCALE 2 : 1

NOTE:

1. GRIP RANGE: .130 - .225
2. HOLE SIZE: .281 +.004/-0.000 A/F AFTER ALL APPLIED FINISHES.
3. INSTALLED LENGTH: .735 MAX.
4. LUBRICATION: OIL
5. INSTALLATION TOOL: SSG 802 SPIN SPIN

PROPRIETARY AND CONFIDENTIAL
THIS DRAWING, AND THE INFORMATION CONTAINED HEREIN, ARE THE PROPERTY OF SHEREX AND ARE NOT TO BE USED IN ANY MANNER DETRIMENTAL TO THE INTEREST OF THE COMPANY.
SHEREX SOLUTIONS RESERVES THE RIGHT TO REVISE PART/DRAWING WITHOUT NOTICE.

		UNLESS OTHERWISE SPECIFIED:		NAME	DATE
		DIMENSIONS ARE IN INCHES TOLERANCES: ANGULAR: MACH ± 1 BEND ± 1 TWO PLACE DECIMAL ± .01 THREE PLACE DECIMAL ± .002	DRAWN	JLA	8/11/03
		INTERPRET GEOMETRIC TOLERANCING PER: ASME Y14.5M-1994	CHECKED		
		MATERIAL	ENG APPR.	JLA	8/11/03
		C1008/C1010	MFG APPR.	AJP	8/11/03
		FINISH	Q.A.		
		ZINC PLATE W/YELLOW TRIVALENT CHROMATE PER SFS-01-001, SC2	COMMENTS:	E-mail: info@sherex.com www.sherex.com Phone: 866-474-3739 Fax: 716-875-0358	
NEXT ASSY	USED ON				
APPLICATION		DO NOT SCALE DRAWING			

		
TITLE:		
LARGE FLANGE SEMI-HEX CLOSED END		
SIZE DWG. NO.		REV
A	CAH2-1024-225B	B
SCALE: 2:1	WEIGHT: .0051 kg	SHEET 1 OF 1