

REVISIONS			
REV.	DESCRIPTION	DATE	ECN
A	INITIAL RELEASE	5/23/05	
B	NEW FINISH PER SFS-01-001, SC2	1/16/15	1737

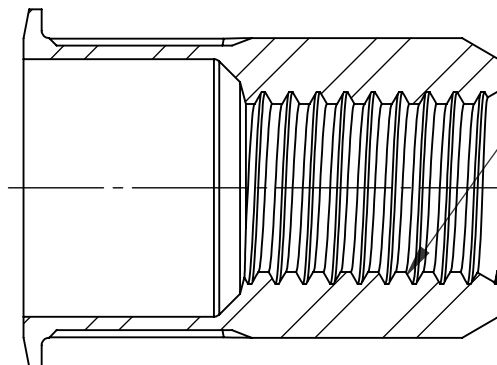
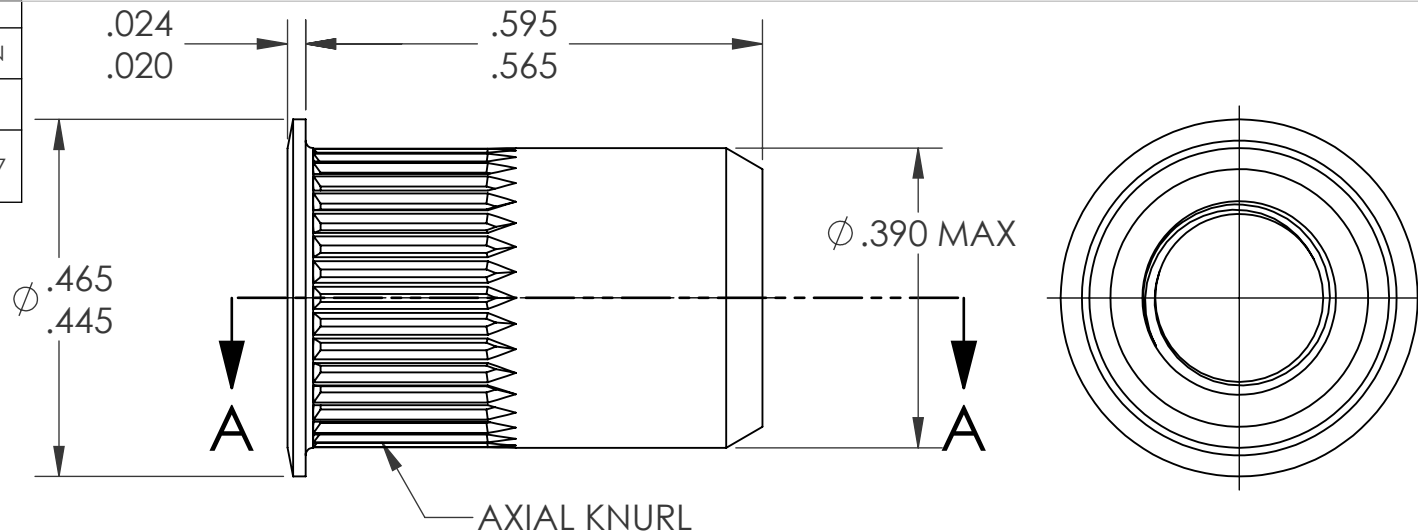

SECTION A-A

NOTE:

- GRIP RANGE: .027 - .165
- HOLE SIZE: .391 +.006/-0.000 AFTER ALL APPLIED FINISHES.
- INSTALLED LENGTH: .380 MAX.
- LUBRICATION: WAX
- INSTALLATION TOOL: SSG 802 SPIN SPIN

**PROPRIETARY AND CONFIDENTIAL**  
 THIS DRAWING, AND THE INFORMATION CONTAINED HEREIN, ARE THE PROPERTY OF SHEREX AND ARE NOT TO BE USED IN ANY MANNER DETRIMENTAL TO THE INTEREST OF THE COMPANY.  
 SHEREX SOLUTIONS RESERVES THE RIGHT TO REVISE PART/DRAWING WITHOUT NOTICE.

		UNLESS OTHERWISE SPECIFIED:	NAME	DATE
		DIMENSIONS ARE IN INCHES TOLERANCES: ANGULAR: MACH ± 1 BEND ± 1 TWO PLACE DECIMAL ± .01 THREE PLACE DECIMAL ± .002	DRAWN	TOO 5/23/05
		INTERPRET GEOMETRIC TOLERANCING PER: ASME Y14.5M-1994	CHECKED	
		MATERIAL	ENG APPR.	TOO 5/23/05
		C1008/C1010	MFG APPR.	AJP 5/23/05
		FINISH	Q.A.	
		ZINC PLATE W/YELLOW TRIVALENT CHROAMTE PER SFS-01-001, SC2	COMMENTS:	
NEXT ASSY	USED ON		E-mail: info@sherex.com	
			www.sherex.com	
			Phone: 866-474-3739	
			Fax: 716-875-0358	
APPLICATION		DO NOT SCALE DRAWING		

		
TITLE:		
SMALL FLANGE OPEN END		
SIZE	DWG. NO.	REV
<b>A</b>	CAK2-2528-165	<b>B</b>
SCALE: 2:1	WEIGHT: .0044 kg	SHEET 1 OF 1