

REVISIONS			
REV.	DESCRIPTION	DATE	ECN
A	INITIAL RELEASE	7/23/05	
B	NEW FINISH PER SFS-01-001, SC2	1/19/15	1739

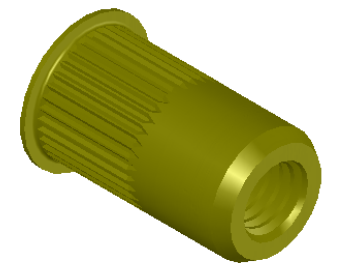
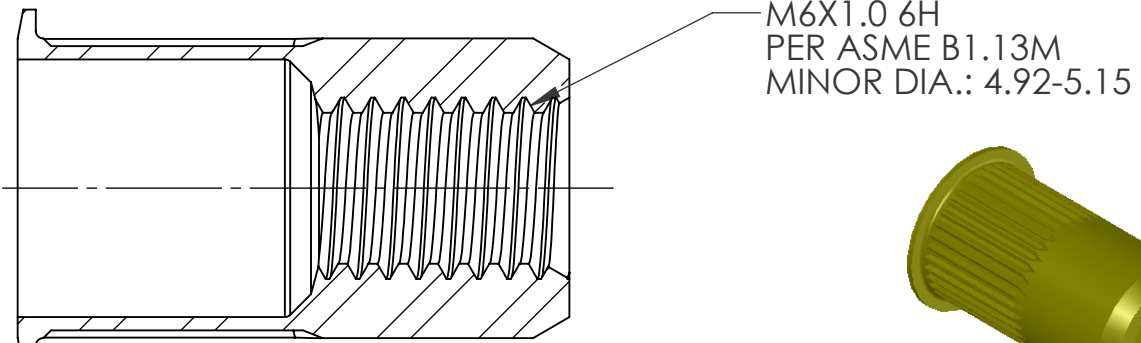
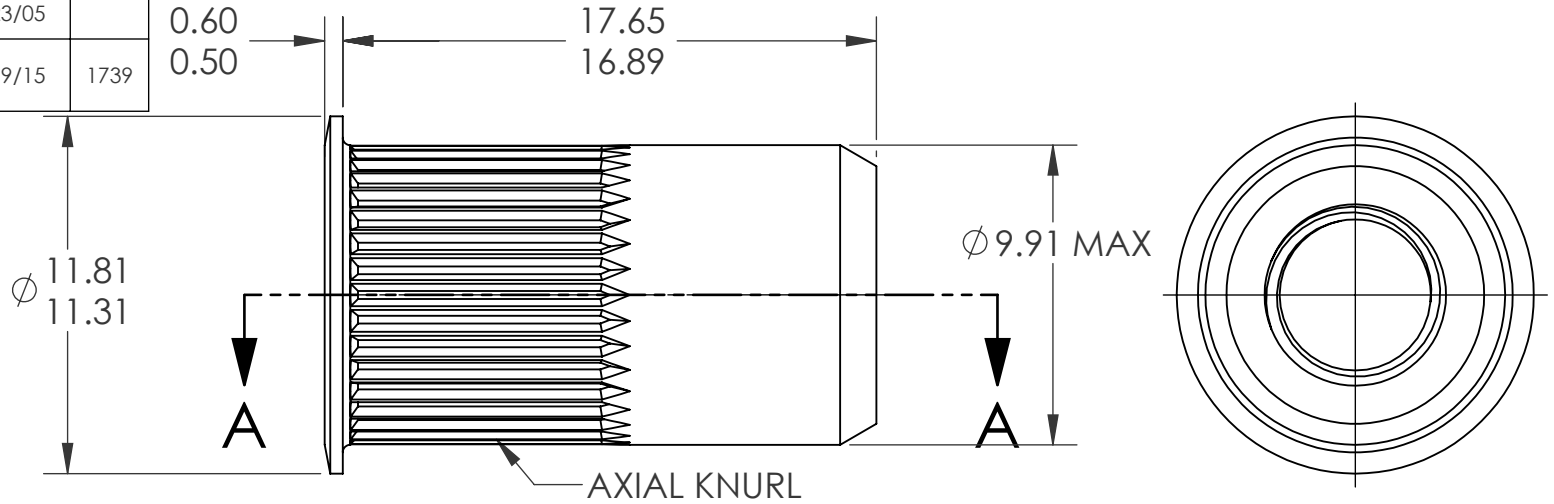

SECTION A-A

- NOTE:
- GRIP RANGE: 4.2 - 6.6
 - HOLE SIZE: 10.00 +0.15/-0.0 AFTER ALL APPLIED FINISHES.
 - INSTALLED LENGTH: 9.65 MAX.
 - LUBRICATION: WAX
 - INSTALLATION TOOL: SSG 802 SPIN SPIN

PROPRIETARY AND CONFIDENTIAL
 THIS DRAWING, AND THE INFORMATION CONTAINED HEREIN, ARE THE PROPERTY OF SHEREX AND ARE NOT TO BE USED IN ANY MANNER DETRIMENTAL TO THE INTEREST OF THE COMPANY.
 SHEREX SOLUTIONS RESERVES THE RIGHT TO REVISE PART/DRAWING WITHOUT NOTICE.

			UNLESS OTHERWISE SPECIFIED:	NAME	DATE
			DIMENSIONS ARE IN MILLIMETERS TOLERANCES: ANGULAR: MACH ± 1 BEND ± 1 ONE PLACE DECIMAL ± 0.10 TWO PLACE DECIMAL ± 0.05	DRAWN	TOO 7/23/05
			INTERPRET GEOMETRIC TOLERANCING PER: ASME Y14.5M-1994	CHECKED	
			MATERIAL	ENG APPR.	TOO 7/23/05
			C1008/C1010	MFG APPR.	AJP 7/23/05
			FINISH	Q.A.	
			ZINC PLATE W/YELLOW TRIVALENT CHROMATE PER SFS-01-001, SC2	COMMENTS:	
NEXT ASSY	USED ON			E-mail: info@sherex.com	
				www.sherex.com	
				Phone: 866-474-3739	
				Fax: 716-875-0358	
			DO NOT SCALE DRAWING		

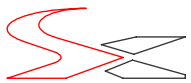
		
TITLE:		
SMALL FLANGE OPEN END		
SIZE	DWG. NO.	REV
A	CAK2-610-6.6	B
SCALE: 2:1	WEIGHT: .0050 kg	SHEET 1 OF 1