

REVISIONS			
REV.	DESCRIPTION	DATE	ECN
A	INITIAL RELEASE	4/22/09	1172

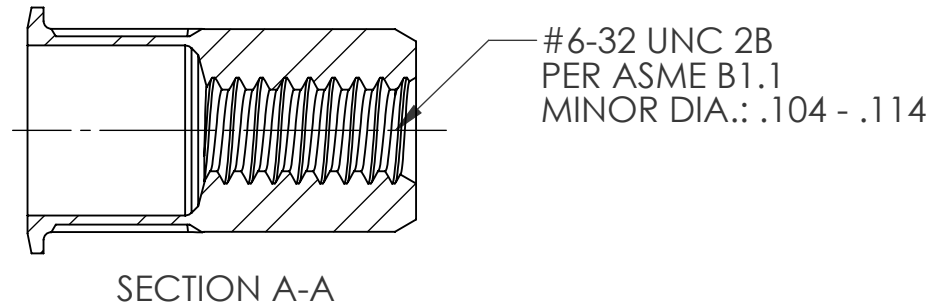
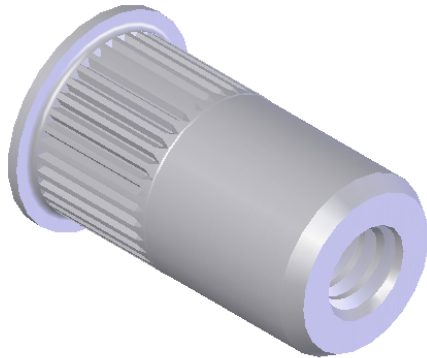
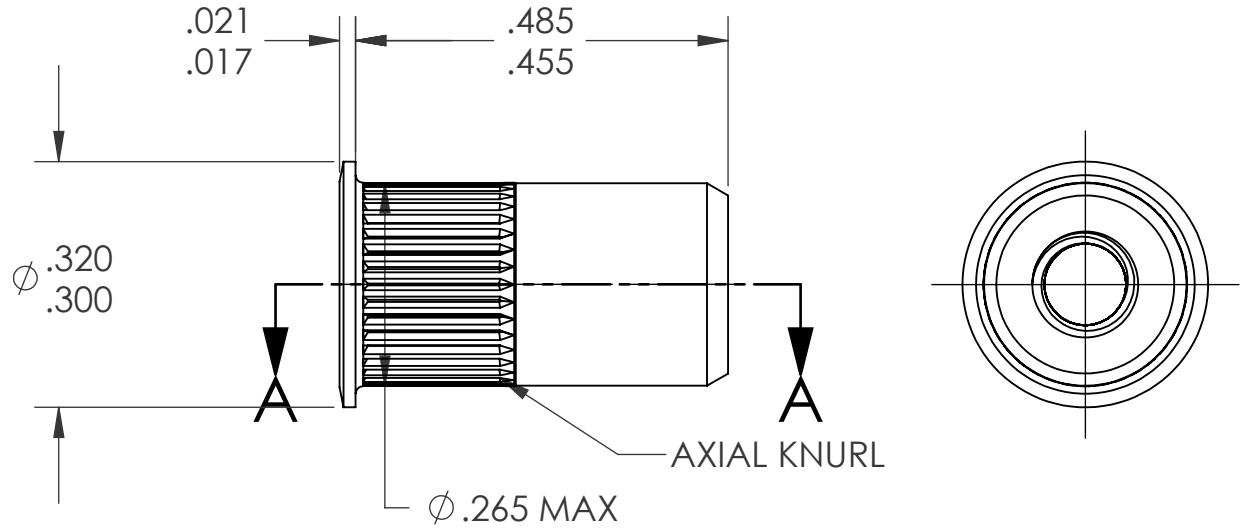

- NOTE:
1. GRIP RANGE: .080 - .130
 2. HOLE SIZE: .266 +.006/-.000 AFTER ALL APPLIED FINISHES.
 3. INSTALLED LENGTH: .305 MAX.
 4. LUBRICATION: WAX
 5. INSTALLATION TOOL: SSG 801 SPIN SPIN

		UNLESS OTHERWISE SPECIFIED:		NAME	DATE			
		DIMENSIONS ARE IN INCHES TOLERANCES: ANGULAR: MACH ±1 BEND ±1 TWO PLACE DECIMAL ±.01 THREE PLACE DECIMAL ±.002		DRAWN	TWR 4/22/09			
		INTERPRET GEOMETRIC TOLERANCING PER: ASME Y14.5M-1994		CHECKED				
		MATERIAL		ENG APPR.	JVK 4/22/09			
		5056 ALUMINUM		MFG APPR.		TITLE: SMALL FLANGE OPEN END		
		FINISH		Q.A.	JVK 4/22/09			
NEXT ASSY		USED ON		COMMENTS:		SIZE DWG. NO.	REV	
				E-mail: info@sherex.com www.sherex.com Phone: 866-474-3739 Fax: 716-875-0358		A CAK3-0632-130	A	
APPLICATION		DO NOT SCALE DRAWING				SCALE: 2:1	WEIGHT: kg	SHEET 1 OF 1

PROPRIETARY AND CONFIDENTIAL
 THIS DRAWING, AND THE INFORMATION CONTAINED HEREIN, ARE THE PROPERTY OF SHEREX AND ARE NOT TO BE USED IN ANY MANNER DETRIMENTAL TO THE INTEREST OF THE COMPANY.
 SHEREX SOLUTIONS RESERVES THE RIGHT TO REVISE PART/DRAWING WITHOUT NOTICE.