

REVISIONS			
REV.	DESCRIPTION	DATE	ECN
A	INITIAL RELEASE	4/22/09	1172

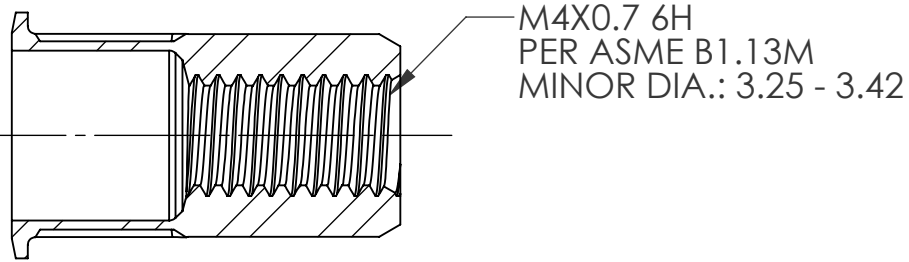

SECTION A-A

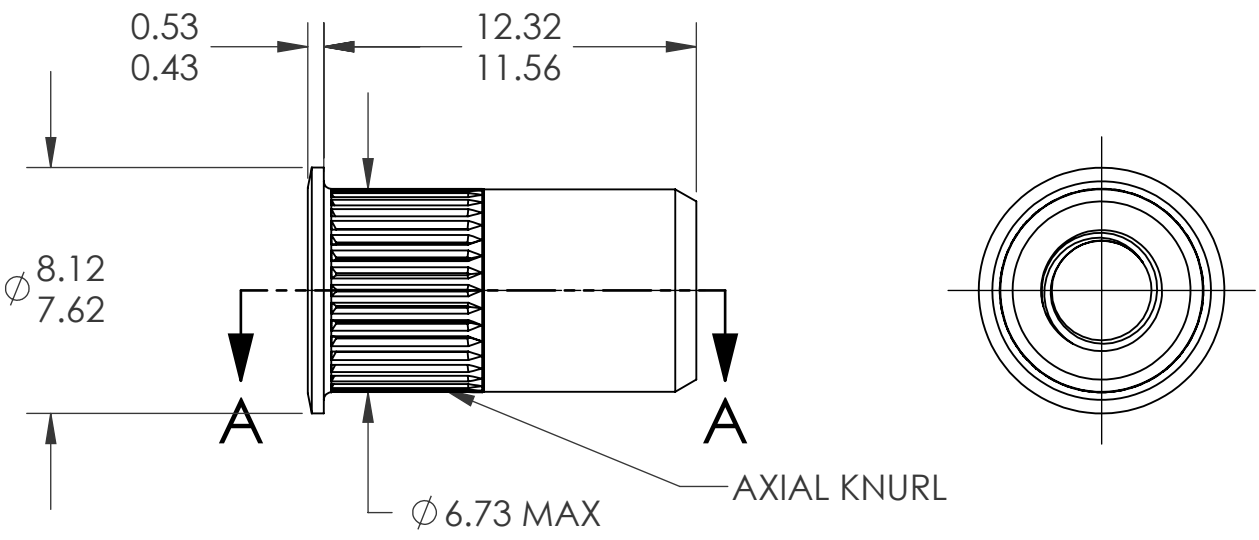
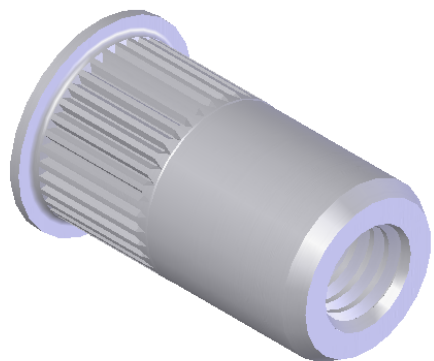

- NOTE:
- GRIP RANGE: 2.0 - 3.3
 - HOLE SIZE: 6.75 +0.15/-0.0 AFTER ALL APPLIED FINISHES.
 - INSTALLED LENGTH: 7.75 MAX.
 - LUBRICATION: WAX
 - INSTALLATION TOOL: SSG 801 SPIN SPIN

PROPRIETARY AND CONFIDENTIAL
 THIS DRAWING, AND THE INFORMATION CONTAINED HEREIN, ARE THE PROPERTY OF SHEREX AND ARE NOT TO BE USED IN ANY MANNER DETRIMENTAL TO THE INTEREST OF THE COMPANY.
 SHEREX SOLUTIONS RESERVES THE RIGHT TO REVISE PART/DRAWING WITHOUT NOTICE.

		UNLESS OTHERWISE SPECIFIED:	NAME	DATE
		DIMENSIONS ARE IN MILLIMETERS TOLERANCES: ANGULAR: MACH ±1 BEND ±1 ONE PLACE DECIMAL ±0.10 TWO PLACE DECIMAL ±0.05	DRAWN	TWR 4/22/09
		INTERPRET GEOMETRIC TOLERANCING PER: ASME Y14.5M-1994	CHECKED	
		MATERIAL	ENG APPR.	JVK 4/22/09
		5056 ALUMINUM	MFG APPR.	
		FINISH	Q.A.	JVK 4/22/09
		NONE	COMMENTS:	
NEXT ASSY	USED ON		E-mail: info@sherex.com	
			www.sherex.com	
			Phone: 866-474-3739	
			Fax: 716-875-0358	
APPLICATION		DO NOT SCALE DRAWING		

		
TITLE:		
SMALL FLANGE OPEN END		
SIZE DWG. NO.	REV	
A CAK3-470-3.3	A	
SCALE: 2:1	WEIGHT: kg	SHEET 1 OF 1