

REVISIONS			
REV.	DESCRIPTION	DATE	ECN
A	INITIAL RELEASE	5/23/05	
B	NEW FINISH PER SFS-01-001, SC2	1/14/15	1735

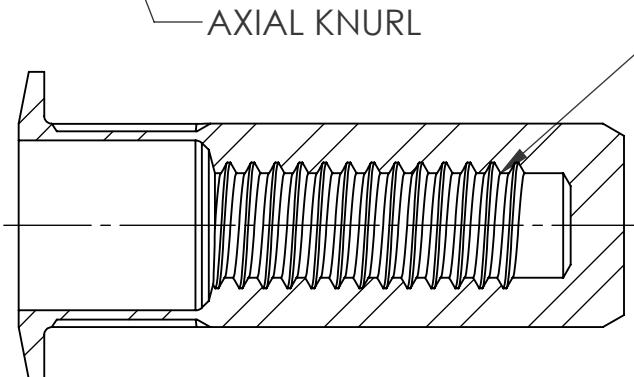
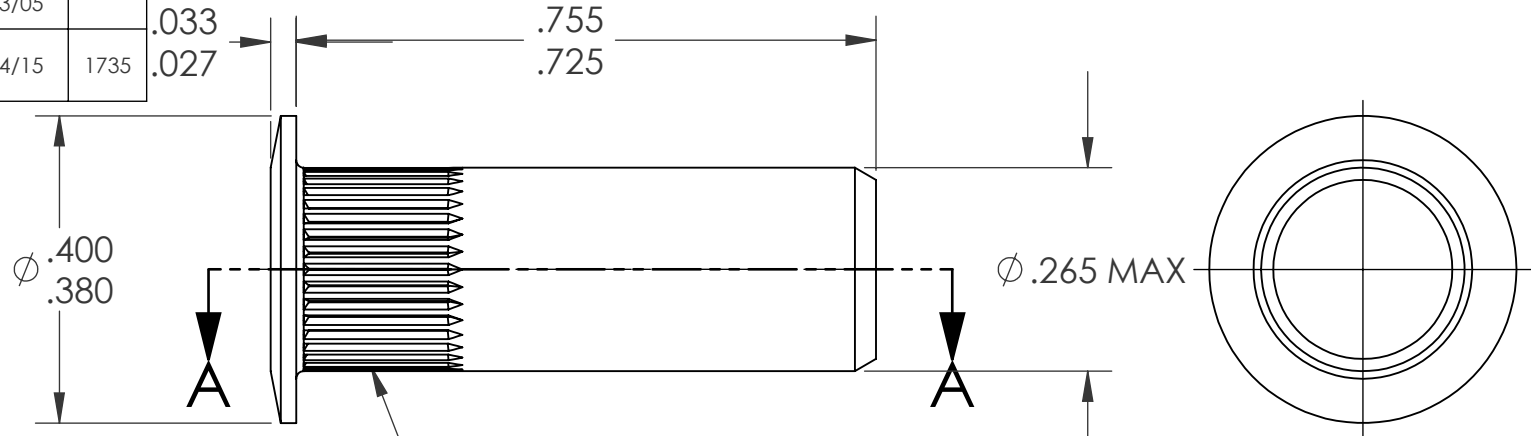

SECTION A-A

- NOTE:
- GRIP RANGE: .080 - .130
  - HOLE SIZE: .266 +.006/-0.000 AFTER ALL APPLIED FINISHES.
  - INSTALLED LENGTH: .580 MAX.
  - INSTALLED THREAD DEPTH: .670 REF.
  - LUBRICATION: OIL
  - INSTALLATION TOOL: SSG 801 SPIN SPIN

**PROPRIETARY AND CONFIDENTIAL**  
 THIS DRAWING, AND THE INFORMATION CONTAINED HEREIN, ARE THE PROPERTY OF SHEREX AND ARE NOT TO BE USED IN ANY MANNER DETRIMENTAL TO THE INTEREST OF THE COMPANY.  
 SHEREX SOLUTIONS RESERVES THE RIGHT TO REVISE PART/DRAWING WITHOUT NOTICE.

		UNLESS OTHERWISE SPECIFIED:		NAME	DATE
		DIMENSIONS ARE IN INCHES TOLERANCES: ANGULAR: MACH ±1 BEND ±1 TWO PLACE DECIMAL ±.01 THREE PLACE DECIMAL ±.002		DRAWN	TOO 5/23/05
		INTERPRET GEOMETRIC TOLERANCING PER: ASME Y14.5M-1994		CHECKED	
		MATERIAL		ENG APPR.	TOO 5/23/05
		C1008/C1010		MFG APPR.	AJP 5/23/05
		FINISH		Q.A.	
		ZINC PLATE W/YELLOW TRIVALENT CHROMATE PER SFS-01-001, SC2		COMMENTS:	
NEXT ASSY	USED ON	E-mail: info@sherex.com www.sherex.com Phone: 866-474-3739 Fax: 716-875-0358			
APPLICATION		DO NOT SCALE DRAWING			

TITLE: LARGE FLANGE CLOSED END		
SIZE	DWG. NO.	REV
<b>A</b>	CAL2-0832-130B	<b>B</b>
SCALE: 2:1	WEIGHT: .0035 kg	SHEET 1 OF 1