

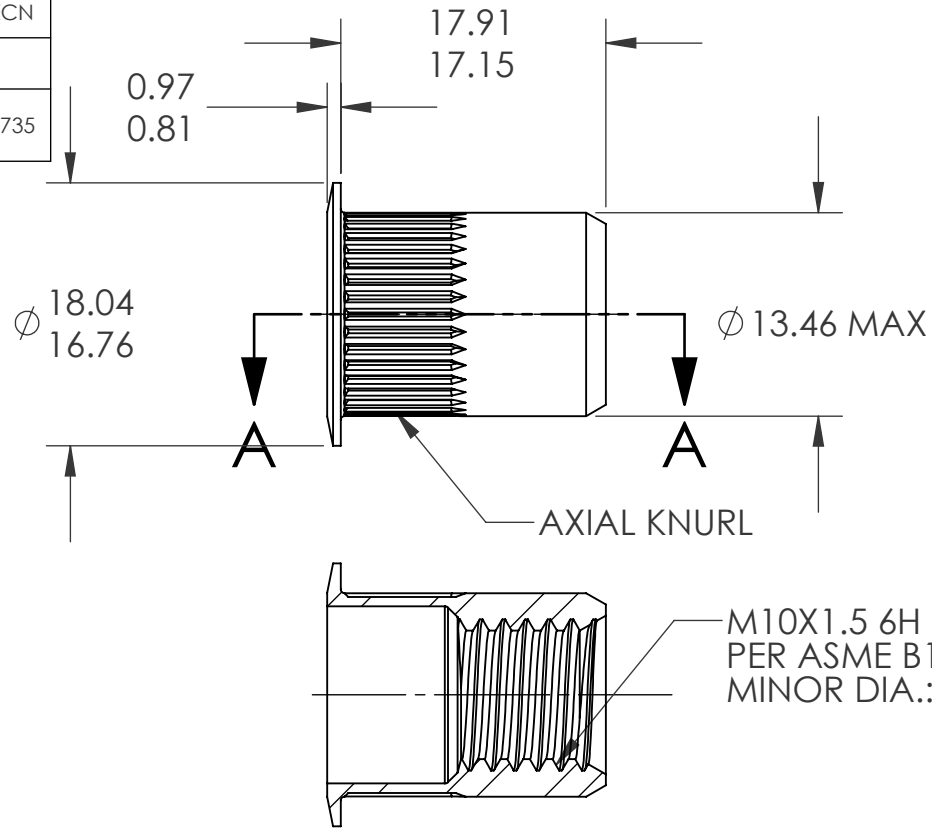

REVISIONS			
REV.	DESCRIPTION	DATE	ECN
A	INITIAL RELEASE	7/20/05	
B	NEW FINISH PER SFS-01-001, SC2	1/14/15	1735



**NOTE:**

- GRIP RANGE: 0.70 - 3.80
- HOLE SIZE: 13.50 +0.15/-0.0 AFTER ALL APPLIED FINISHES.
- INSTALLED LENGTH: 11.94 MAX.
- LUBRICATION: WAX
- INSTALLATION TOOL: SSG 803 SPIN SPIN

SECTION A-A

		UNLESS OTHERWISE SPECIFIED:		NAME	DATE	
		DIMENSIONS ARE IN MILLIMETERS TOLERANCES: ANGULAR: MACH ± 1 BEND ± 1 ONE PLACE DECIMAL ± 0.10 TWO PLACE DECIMAL ± 0.05		DRAWN	TOO	
		INTERPRET GEOMETRIC TOLERANCING PER: ASME Y14.5M-1994		CHECKED		
		MATERIAL		ENG APPR.	TOO	7/20/05
		C1008/1010		MFG APPR.	AJP	7/20/05
		FINISH		Q.A.		
		ZINC PLATE W/YELLOW TRIVALENT CHROMATE PER SFS-01-001, SC2		COMMENTS:		<b>TITLE:</b> <b>LARGE FLANGE OPEN END</b>
NEXT ASSY		USED ON		E-mail: info@sherex.com www.sherex.com Phone: 866-474-3739 Fax: 716-875-0358		
APPLICATION		DO NOT SCALE DRAWING		SIZE DWG. NO.		REV
				<b>A</b> CAL2-1015-3.8		<b>B</b>
				SCALE: 2:1 WEIGHT: .0083 kg		SHEET 1 OF 1

**PROPRIETARY AND CONFIDENTIAL**  
THIS DRAWING, AND THE INFORMATION CONTAINED HEREIN, ARE THE PROPERTY OF SHEREX AND ARE NOT TO BE USED IN ANY MANNER DETRIMENTAL TO THE INTEREST OF THE COMPANY.  
SHEREX SOLUTIONS RESERVES THE RIGHT TO REVISE PART/DRAWING WITHOUT NOTICE.