

REVISIONS			
REV.	DESCRIPTION	DATE	ECN
A	INITIAL RELEASE	5/23/05	
B	NEW FINISH PER SFS-01-001, SC2	1/14/15	1735

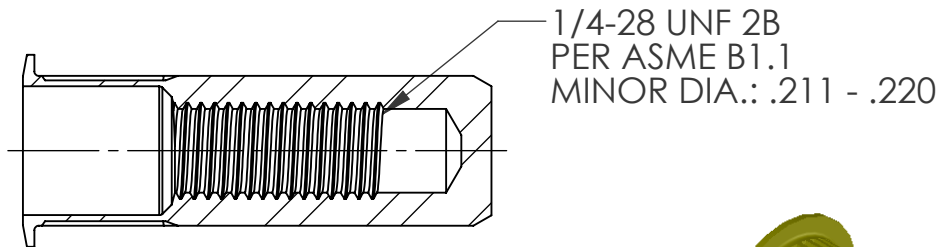

SECTION A-A

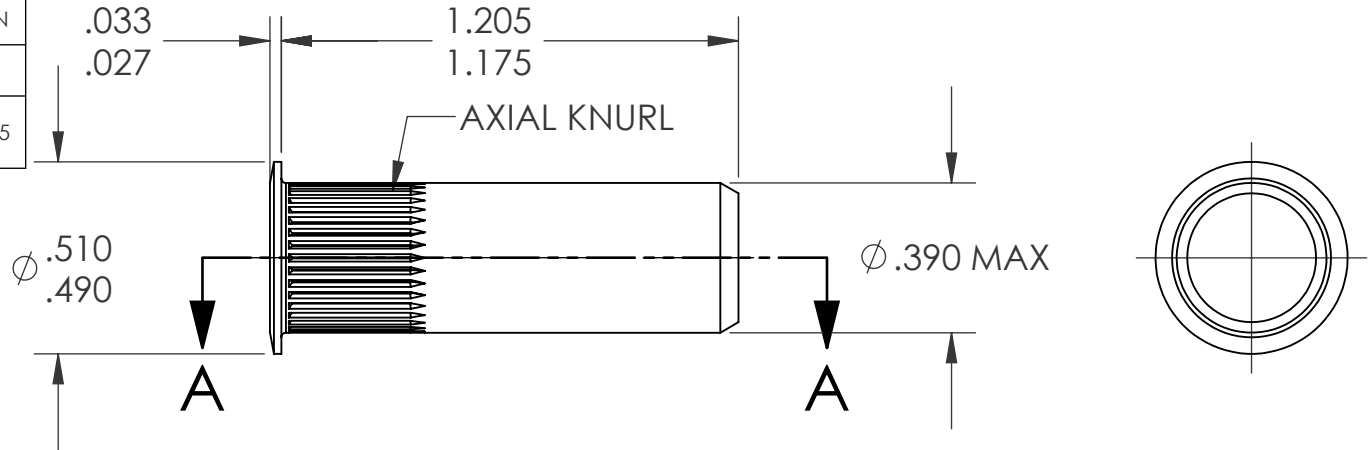
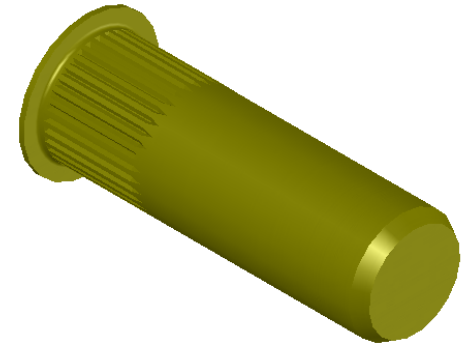

NOTE:

- GRIP RANGE: .165 - .260
- HOLE SIZE: .391 +.006/-0.0 AFTER ALL APPLIED FINISHES.
- INSTALLED LENGTH: .905 MAX.
- INSTALLED THREAD DEPTH: 1.035 REF.
- LUBRICATION: OIL
- INSTALLATION TOOL: SSG 802 SPIN SPIN

PROPRIETARY AND CONFIDENTIAL

THIS DRAWING, AND THE INFORMATION CONTAINED HEREIN, ARE THE PROPERTY OF SHEREX AND ARE NOT TO BE USED IN ANY MANNER DETRIMENTAL TO THE INTEREST OF THE COMPANY.
SHEREX SOLUTIONS RESERVES THE RIGHT TO REVISE PART/DRAWING WITHOUT NOTICE.

		UNLESS OTHERWISE SPECIFIED:		NAME	DATE		
		DIMENSIONS ARE IN INCHES TOLERANCES: ANGULAR: MACH ±1 BEND ±1 TWO PLACE DECIMAL ±.02 THREE PLACE DECIMAL ±.010		DRAWN	TOO		5/23/05
		INTERPRET GEOMETRIC TOLERANCING PER: ASME Y14.5M-1994		CHECKED			
		MATERIAL C1008/C1010		ENG APPR.	TOO		5/23/05
		FINISH ZINC PLATE W/YELLOW TRIVALENT CHROMATE PER SFS-01-001, SC2		MFG APPR.	AJP	5/23/05	
NEXT ASSY	USED ON			Q.A.			
APPLICATION		DO NOT SCALE DRAWING		COMMENTS: E-mail: info@sherex.com www.sherex.com Phone: 866-474-3739 Fax: 716-875-0315		TITLE: LARGE FLANGE, CLOSED END	
				SIZE DWG. NO.		REV	
				A	CAL2-2528-260B	B	
				SCALE: 2:1	WEIGHT: .0106 kg	SHEET 1 OF 1	