

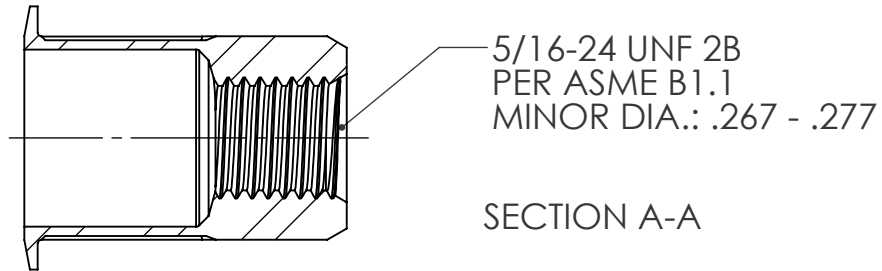

REVISIONS			
REV.	DESCRIPTION	DATE	ECN
A	INITIAL RELEASE	11/3/06	
B	NEW FINISH PER SFS-01-001, SC2	1/12/15	1732

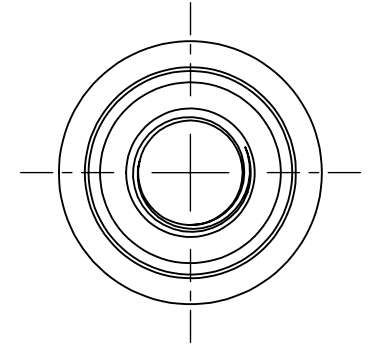
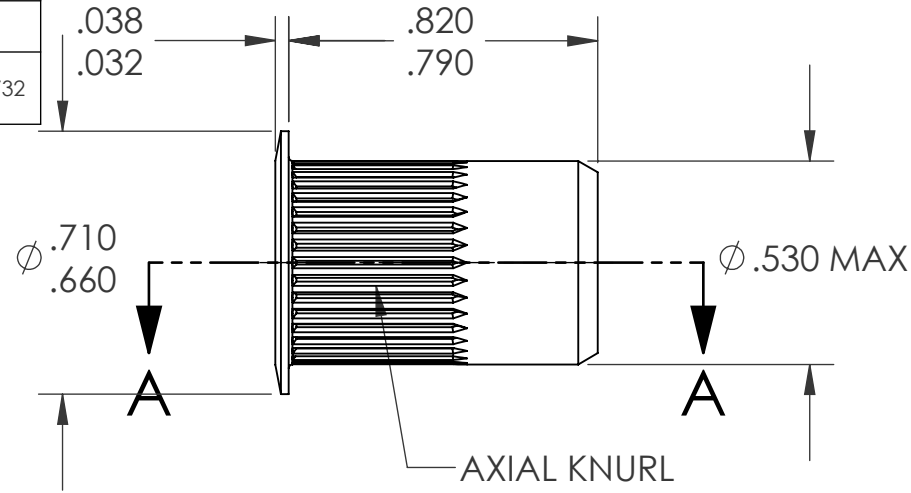
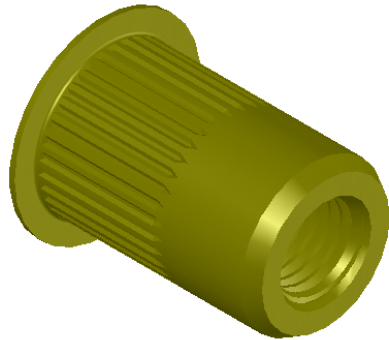

NOTE:

- GRIP RANGE: .150 - .312
- HOLE SIZE: .531 +.006/-.000 AFTER ALL APPLIED FINISHES.
- INSTALLED LENGTH: .425 MAX.
- LUBRICATION: WAX
- INSTALLATION TOOL: SSG 803 SPIN SPIN

**PROPRIETARY AND CONFIDENTIAL**  
 THIS DRAWING, AND THE INFORMATION CONTAINED HEREIN, ARE THE PROPERTY OF SHEREX AND ARE NOT TO BE USED IN ANY MANNER DETRIMENTAL TO THE INTEREST OF THE COMPANY.  
 SHEREX SOLUTIONS RESERVES THE RIGHT TO REVISE PART/DRAWING WITHOUT NOTICE.

		UNLESS OTHERWISE SPECIFIED:		NAME	DATE	
		DIMENSIONS ARE IN INCHES TOLERANCES: ANGULAR: MACH ± 1 BEND ± 1 TWO PLACE DECIMAL ± .01 THREE PLACE DECIMAL ± .002	DRAWN	TOO	11/3/06	
		INTERPRET GEOMETRIC TOLERANCING PER: ASME Y14.5M-1994	CHECKED			
		MATERIAL C1008/1010	ENG APPR.	TOO	11/3/06	
		FINISH ZINC PLATE W/YELLOW TRIVALENT CHROMATE PER SFS-01-001, SC2	MFG APPR.	AJP	11/3/06	TITLE: LARGE FLANGE OPEN END
NEXT ASSY	USED ON		Q.A.			SIZE DWG. NO. <b>A</b> CAL2-3124-312
APPLICATION		DO NOT SCALE DRAWING	COMMENTS: E-mail: info@sherex.com www.sherex.com Phone: 866-474-3739 Fax: 716-875-0358			REV B
						SCALE: 2:1 WEIGHT:.0104 kg SHEET 1 OF 1