

REVISIONS			
REV.	DESCRIPTION	DATE	ECN
A	INITIAL RELEASE	5/23/05	
B	NEW FINISH PER SFS-01-001, SC2	1/16/15	1737

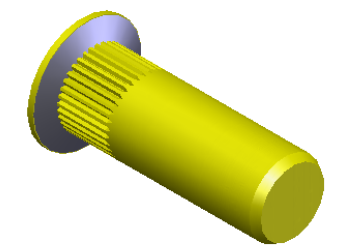
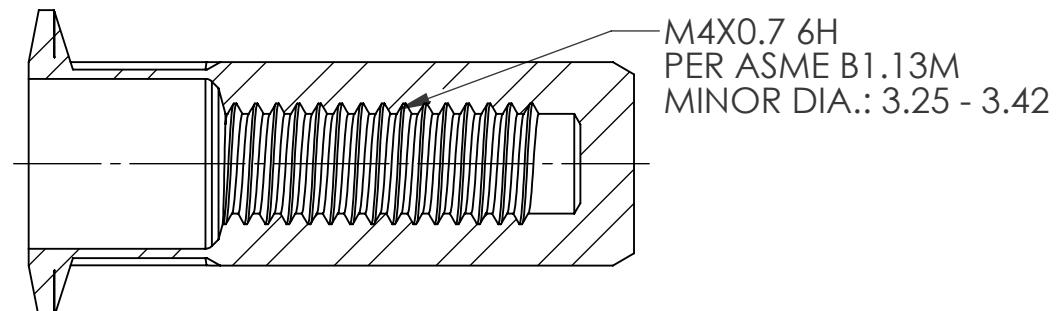
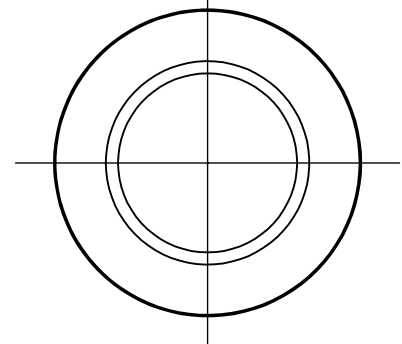
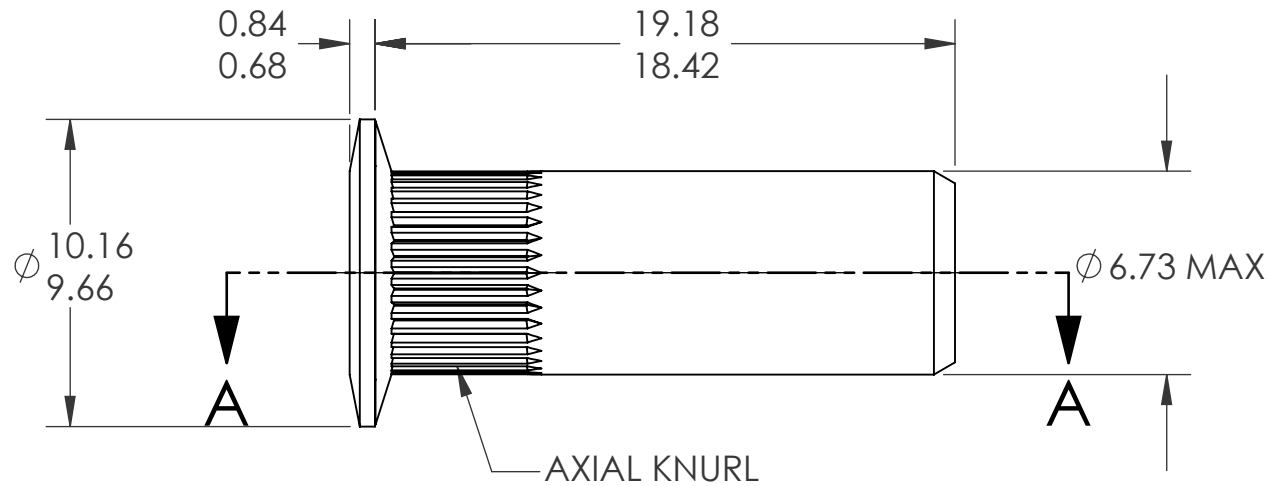

NOTE:

- GRIP RANGE: 2.0 - 3.3
- HOLE SIZE: 6.75 +0.15/-0.0 AFTER ALL APPLIED FINISHES.
- INSTALLED LENGTH: 14.73 MAX.
- INSTALLED THREAD DEPTH: 17.02 REF.
- LUBRICATION: OIL
- INSTALLATION TOOL: SSG 801 SPIN SPIN

SECTION A-A

PROPRIETARY AND CONFIDENTIAL

THIS DRAWING, AND THE INFORMATION CONTAINED HEREIN, ARE THE PROPERTY OF SHEREX AND ARE NOT TO BE USED IN ANY MANNER DETRIMENTAL TO THE INTEREST OF THE COMPANY.
SHEREX SOLUTIONS RESERVES THE RIGHT TO REVISE PART/DRAWING WITHOUT NOTICE.

			UNLESS OTHERWISE SPECIFIED:		NAME	DATE
			DIMENSIONS ARE IN MILLIMETERS TOLERANCES: ANGULAR: MACH ± 1 BEND ± 1 ONE PLACE DECIMAL ± 0.10 TWO PLACE DECIMAL ± 0.05	DRAWN	TOO	5/23/05
			INTERPRET GEOMETRIC TOLERANCING PER: ASME Y14.5M-1994	CHECKED		
			MATERIAL	ENG APPR.	TOO	5/23/05
			C1008/C1010	MFG APPR.	AJP	5/23/05
			FINISH	Q.A.		
			ZINC PLATE W/YELLOW TRIVALENT CHROMATE PER SFS-01-001, SC2	COMMENTS:	E-mail: info@sherex.com www.sherex.com Phone: 866-474-3739 Fax: 716-875-0358	
NEXT ASSY	USED ON					
APPLICATION			DO NOT SCALE DRAWING			

		
TITLE:		
LARGE FLANGE CLOSED END		
SIZE DWG. NO.		REV
A	CAL2-470-3.3B	B
SCALE: 2:1	WEIGHT: .0036 kg	SHEET 1 OF 1