

REVISIONS			
REV.	DESCRIPTION	DATE	ECN
A	INITIAL RELEASE	7/20/05	N/A
B	UPDATE PLATING SPEC	6/28/11	1428
C	NEW FINISH PER SFS-01-001, SC2	1/12/15	1732

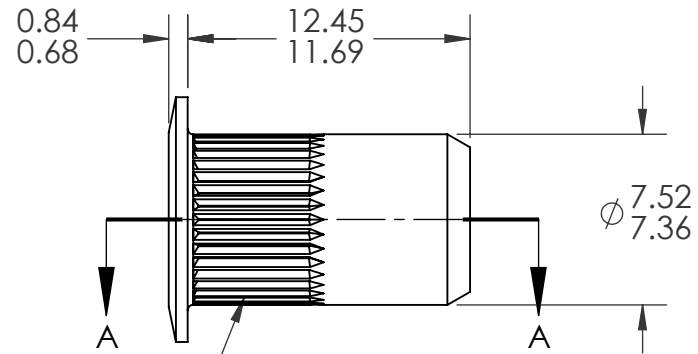

AXIAL KNURL

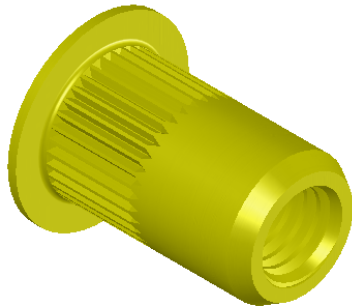
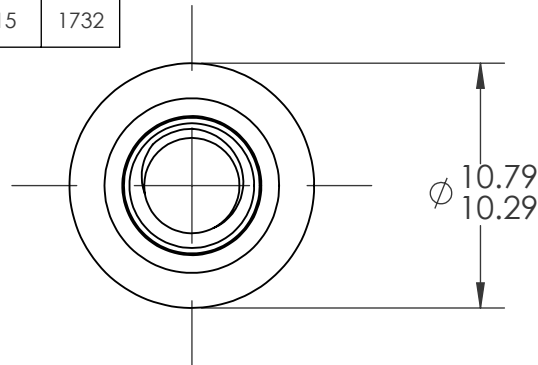
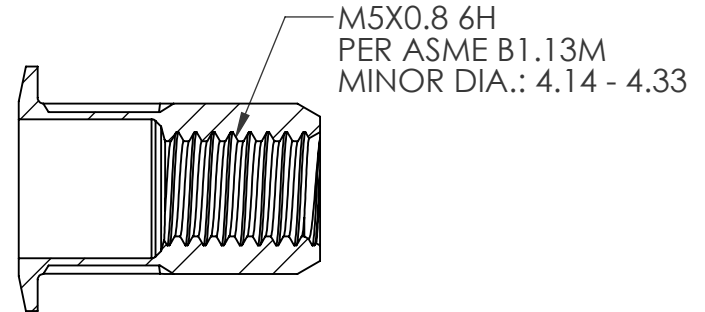

SECTION A-A
SCALE 3 : 1

NOTE:

- GRIP RANGE: 0.5 - 3.3
- HOLE SIZE: 7.60 +0.15/-0.0 AFTER ALL APPLIED FINISHES.
- INSTALLED LENGTH: 8.00 MAX.
- LUBRICATION: WAX
- INSTALLATION TOOL: SSG 802 SPIN SPIN

PROPRIETARY AND CONFIDENTIAL

THIS DRAWING, AND THE INFORMATION CONTAINED HEREIN, ARE THE PROPERTY OF SHEREX AND ARE NOT TO BE USED IN ANY MANNER DETRIMENTAL TO THE INTEREST OF THE COMPANY.
SHEREX SOLUTIONS RESERVES THE RIGHT TO REVISE PART/DRAWING WITHOUT NOTICE.

		UNLESS OTHERWISE SPECIFIED:		NAME	DATE
		DIMENSIONS ARE IN MILLIMETERS TOLERANCES: ANGULAR: MACH ± 1 BEND ± 1 ONE PLACE DECIMAL ± 0.10 TWO PLACE DECIMAL ± 0.05	DRAWN	TOO	7/20/05
		INTERPRET GEOMETRIC TOLERANCING PER: ASME Y14.5M-1994	CHECKED		
		MATERIAL	ENG APPR.	TOO	7/20/05
		C1008/C1010	MFG APPR.	AJP	7/20/05
		FINISH	Q.A.		
		ZINC PLATE W/YELLOW TRIVALENT CHROMATE PER SFS-01-001, SC2	COMMENTS:		
NEXT ASSY	USED ON		E-mail: info@sherex.com		
			www.sherex.com		
			Phone: 866-474-3739		
			Fax: 716-875-0358		
APPLICATION		DO NOT SCALE DRAWING			



TITLE:
LARGE FLANGE OPEN END

SIZE DWG. NO.	REV
A CAL2-580-3.3	C

SCALE: 2:1 WEIGHT: .0023 kg SHEET 1 OF 1