

REVISIONS			
REV.	DESCRIPTION	DATE	ECN
A	INITIAL RELEASE	7/20/05	
B	NEW FINISH PER SFS-01-001, SC2	1/14/15	1735

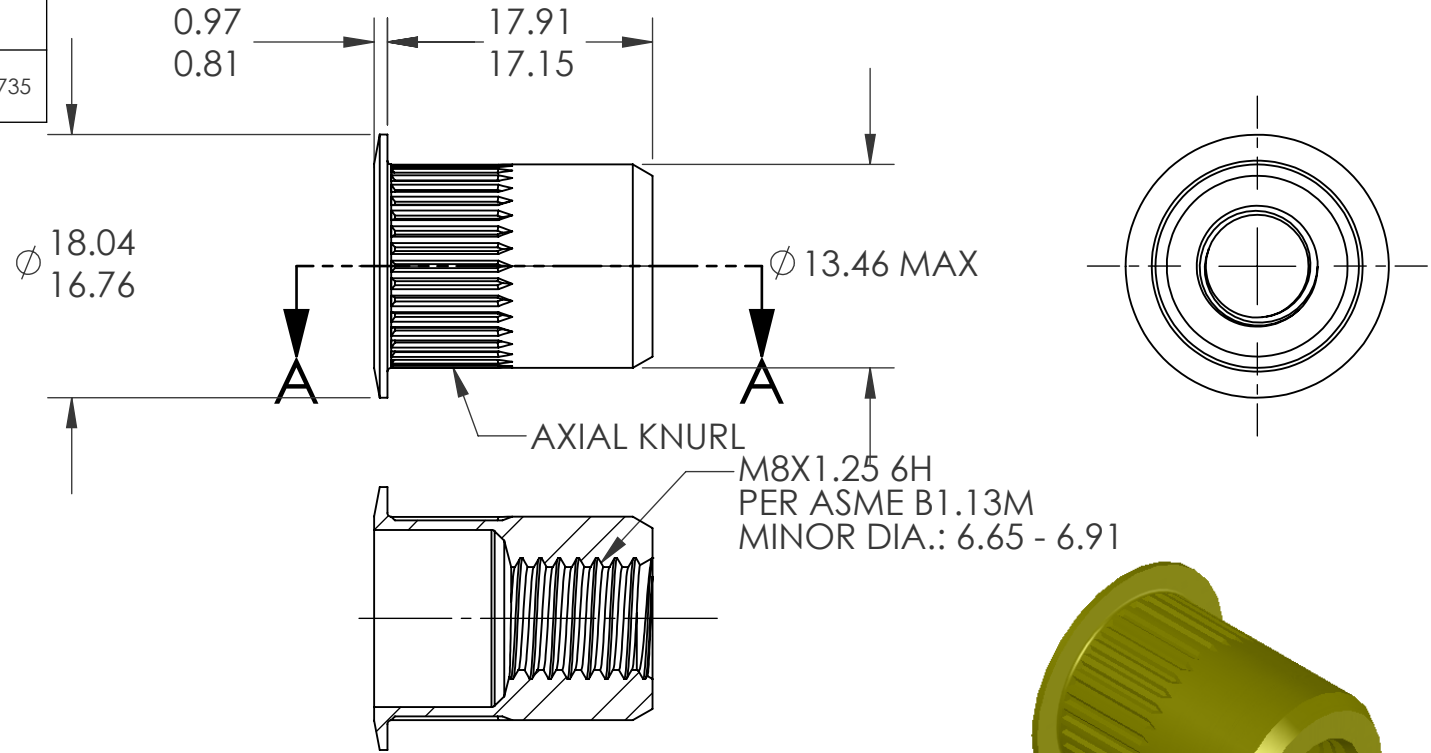

SECTION A-A

NOTE:

- GRIP RANGE: 0.7 - 3.8
- HOLE SIZE: 13.50 +0.15/-0.0 AFTER ALL APPLIED FINISHES.
- INSTALLED LENGTH: 11.94 MAX.
- LUBRICATION: WAX
- INSTALLATION TOOL: SSG 803 SPIN SPIN

PROPRIETARY AND CONFIDENTIAL

THIS DRAWING, AND THE INFORMATION CONTAINED HEREIN, ARE THE PROPERTY OF SHEREX AND ARE NOT TO BE USED IN ANY MANNER DETRIMENTAL TO THE INTEREST OF THE COMPANY.
SHEREX SOLUTIONS RESERVES THE RIGHT TO REVISE PART/DRAWING WITHOUT NOTICE.

		UNLESS OTHERWISE SPECIFIED:		NAME	DATE
		DIMENSIONS ARE IN MILLIMETERS TOLERANCES: ANGULAR: MACH ± 1 BEND ± 1 ONE PLACE DECIMAL ± 0.10 TWO PLACE DECIMAL ± 0.05	DRAWN	TOO	7/20/05
		INTERPRET GEOMETRIC TOLERANCING PER: ASME Y14.5M-1994	CHECKED		
		MATERIAL	ENG APPR.	TOO	7/20/05
		C1008/1010	MFG APPR.	AJP	7/20/05
		FINISH	Q.A.		
		ZINC PLATE W/YELLOW TRIVALENT CHROMATE PER SFS-01-001, SC2	COMMENTS:	E-mail: info@sherex.com www.sherex.com Phone: 866-474-3739 Fax: 716-875-0358	
NEXT ASSY	USED ON				
APPLICATION		DO NOT SCALE DRAWING			



TITLE:

LARGE FLANGE OPEN END

SIZE DWG. NO.

A CAL2-8125-3.8

REV

B

SCALE: 2:1 WEIGHT: .0102 kg

SHEET 1 OF 1