

REVISIONS			
REV.	DESCRIPTION	DATE	ECN
A	INITIAL RELEASE	5/8/09	1179

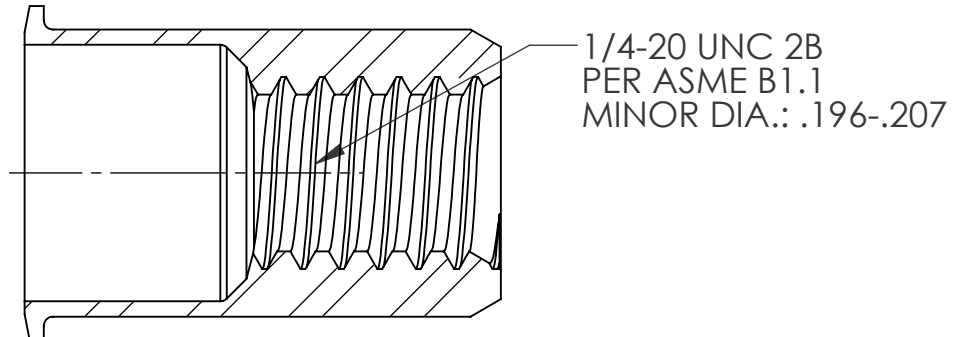
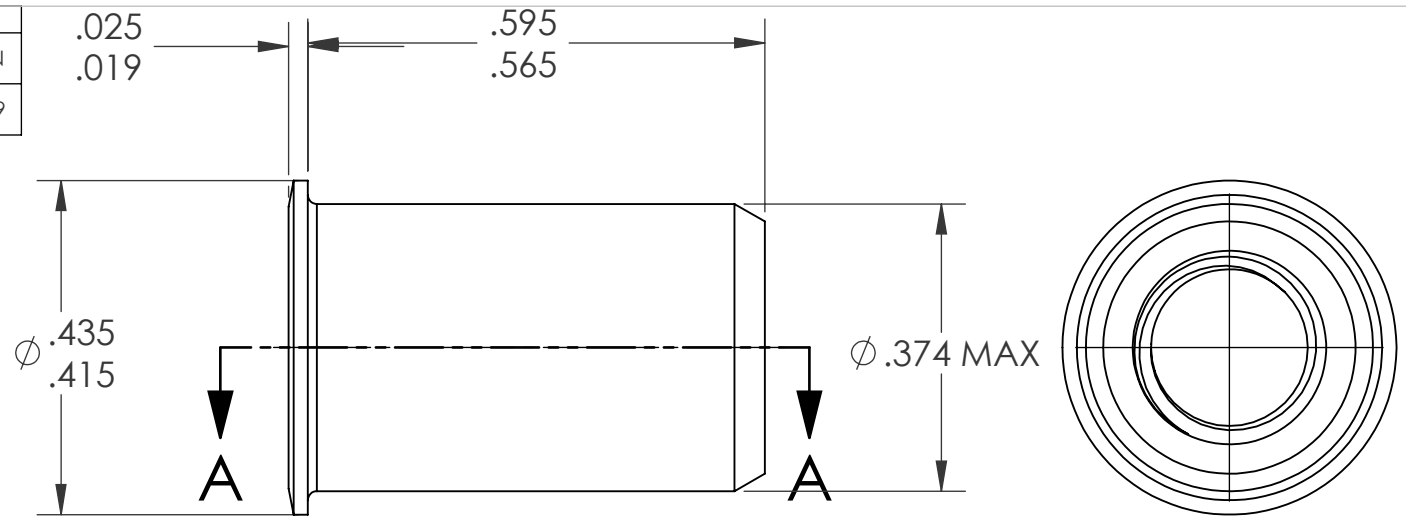

SECTION A-A

NOTE:

1. GRIP RANGE: .030 - .165
2. HOLE SIZE: .375 +.006/-.000 AFTER ALL APPLIED FINISHES.
3. INSTALLED LENGTH: .440 MAX.
4. LUBRICATION: WAX
5. INSTALLATION TOOL: SSG 802 SPIN SPIN

**PROPRIETARY AND CONFIDENTIAL**  
 THIS DRAWING, AND THE INFORMATION CONTAINED HEREIN, ARE THE PROPERTY OF SHEREX AND ARE NOT TO BE USED IN ANY MANNER DETRIMENTAL TO THE INTEREST OF THE COMPANY.  
 SHEREX SOLUTIONS RESERVES THE RIGHT TO REVISE PART/DRAWING WITHOUT NOTICE.

		UNLESS OTHERWISE SPECIFIED:		NAME	DATE		
		DIMENSIONS ARE IN INCHES TOLERANCES: ANGULAR: MACH ±1 BEND ±1 TWO PLACE DECIMAL ±.01 THREE PLACE DECIMAL ±.002		DRAWN	TWR		5/8/09
		INTERPRET GEOMETRIC TOLERANCING PER: ASME Y14.5M-1994		CHECKED			
		MATERIAL		ENG APPR.	JVK		5/8/09
		5056 ALUMINUM		MFG APPR.			
		FINISH		Q.A.	JVK	5/8/09	
		NONE		COMMENTS:		<b>TITLE:</b> SMALL FLANGE SMOOTH BODY	
NEXT ASSY	USED ON			E-mail: <a href="mailto:info@sherex.com">info@sherex.com</a> www.sherex.com Phone: 866-474-3739 Fax: 716-875-0358			SIZE DWG. NO. <b>A</b> CAO3-2520-165
APPLICATION		DO NOT SCALE DRAWING					REV A
				SCALE: 2:1	WEIGHT: kg	SHEET 1 OF 1	