

REVISIONS			
REV.	DESCRIPTION	DATE	ECN
A	INITIAL RELEASE	5/8/09	1179

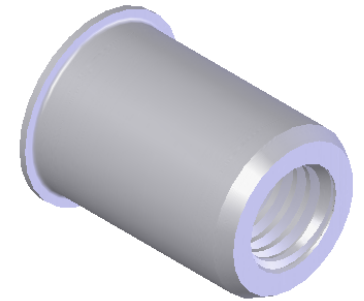
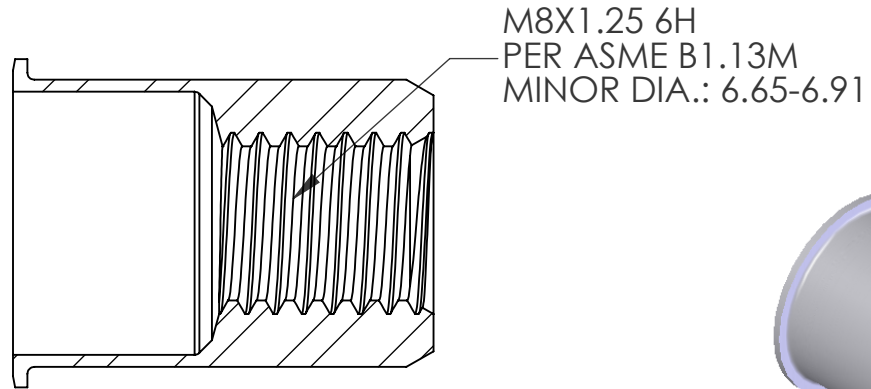
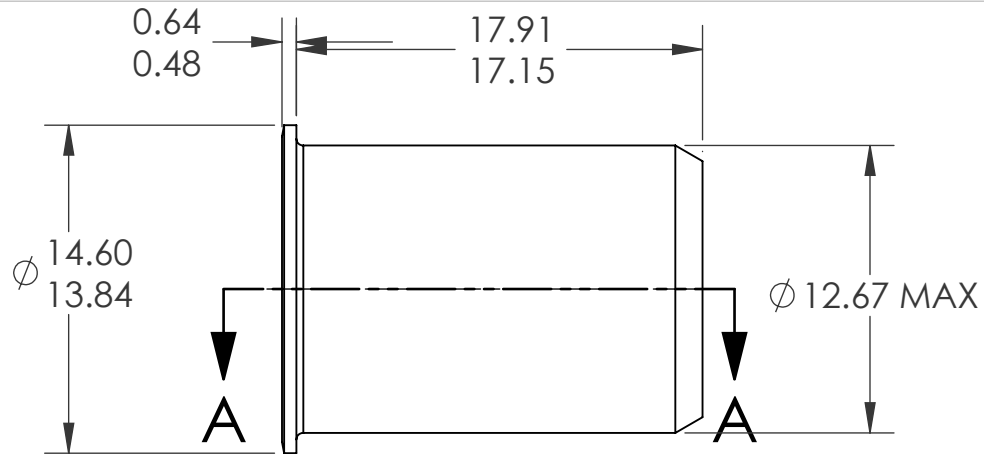

NOTE:

- GRIP RANGE: 1.02 - 5.10
- HOLE SIZE: 12.70 +0.15/-0.0 AFTER ALL APPLIED FINISHES.
- INSTALLED LENGTH: 13.72 MAX.
- LUBRICATION: WAX
- INSTALLATION TOOL: SSG 803 SPIN SPIN

SECTION A-A
SCALE 3 : 1

PROPRIETARY AND CONFIDENTIAL
THIS DRAWING, AND THE INFORMATION CONTAINED HEREIN, ARE THE PROPERTY OF SHEREX AND ARE NOT TO BE USED IN ANY MANNER DETRIMENTAL TO THE INTEREST OF THE COMPANY.
SHEREX SOLUTIONS RESERVES THE RIGHT TO REVISE PART/DRAWING WITHOUT NOTICE.

		UNLESS OTHERWISE SPECIFIED:		NAME	DATE		
		DIMENSIONS ARE IN MILLIMETERS TOLERANCES: ANGULAR: MACH ± 1 BEND ± 1 ONE PLACE DECIMAL ± 0.10 TWO PLACE DECIMAL ± 0.05		DRAWN	TWR		5/8/09
		INTERPRET GEOMETRIC TOLERANCING PER: ASME Y14.5M-1994		CHECKED			
		MATERIAL		ENG APPR.	JVK		5/8/09
		5056 ALUMINUM		MFG APPR.			
		FINISH		Q.A.	JVK	5/8/09	
		NONE		COMMENTS:		TITLE: SMALL FLANGE SMOOTH BODY	
NEXT ASSY	USED ON			E-mail: info@sherex.com www.sherex.com Phone: 866-474-3739 Fax: 716-875-0358			
APPLICATION		DO NOT SCALE DRAWING		SIZE DWG. NO.	REV		
				A	CAO3-8125-5.1	A	
				SCALE: 2:1	WEIGHT: kg	SHEET 1 OF 1	