

REVISIONS			
REV.	DESCRIPTION	DATE	ECN
A	INITIAL RELEASE	5/20/09	1184

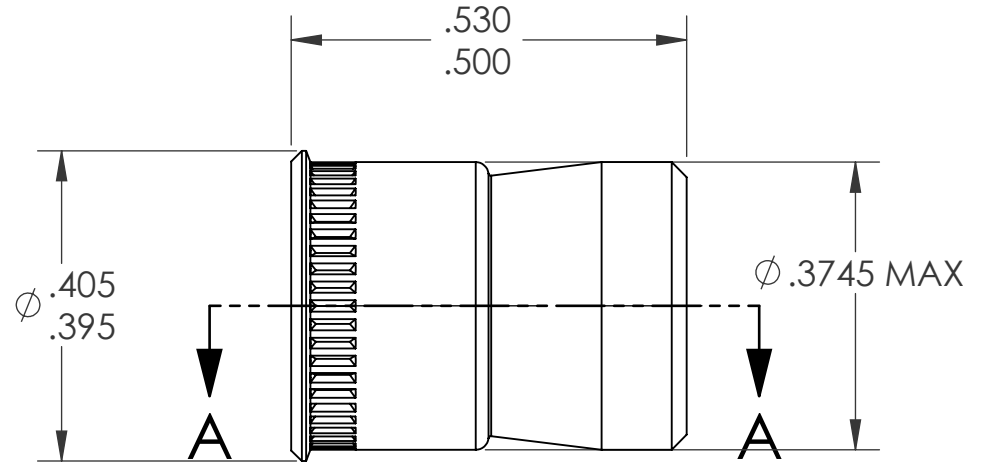

1/4-20 UNC "OVER SIZE"
NON-GAUGEABLE THREAD

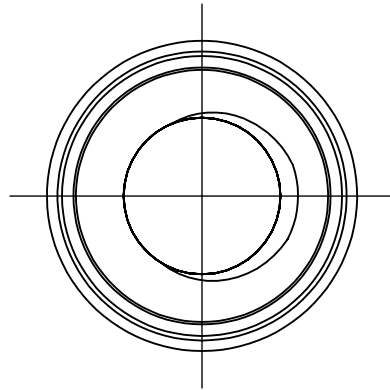
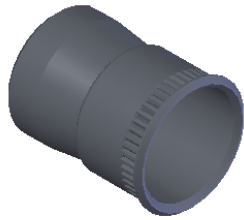
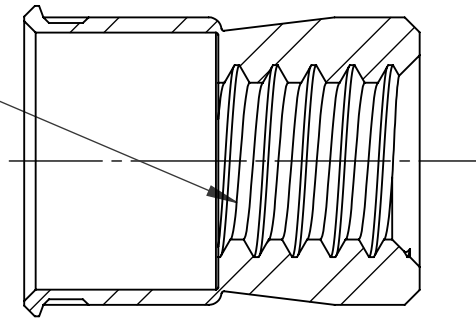

SECTION A-A

NOTE:

1. GRIP RANGE: .030 MIN.
2. HOLE SIZE:
 1. .030 - .090 MT'L THICK.: .3750 AFTER ALL APPLIED FINISHES.
 2. .091 - .124 MT'L THICK.: .3750 AFTER ALL APPLIED FINISHES.
 3. .125 - .186 MT'L THICK.: .3860 AFTER ALL APPLIED FINISHES.
 4. .187 - OVER MT'L THICK.: .3906 AFTER ALL APPLIED FINISHES.
3. INSTALLED LENGTH: N/A
4. LUBRICATION: NONE
5. INSTALLATION TOOL: SSG 802 SPIN SPIN

PROPRIETARY AND CONFIDENTIAL

THIS DRAWING, AND THE INFORMATION CONTAINED HEREIN, ARE THE PROPERTY OF SHEREX AND ARE NOT TO BE USED IN ANY MANNER DETRIMENTAL TO THE INTEREST OF THE COMPANY.
SHEREX SOLUTIONS RESERVES THE RIGHT TO REVISE PART/DRAWING WITHOUT NOTICE.

		UNLESS OTHERWISE SPECIFIED:	NAME	DATE
		DIMENSIONS ARE IN INCHES TOLERANCES: ANGULAR: MACH ± 1 BEND ± 1 TWO PLACE DECIMAL ± .01 THREE PLACE DECIMAL ± .002	DRAWN	TWR 5/20/09
		INTERPRET GEOMETRIC TOLERANCING PER: ASME Y14.5M-1994	CHECKED	
		MATERIAL	ENG APPR.	JVK 5/20/09
		304L STAINLESS	MFG APPR.	
		FINISH	Q.A.	JVK 5/20/09
		TIN ALLOY PER ASTM B545	COMMENTS:	
NEXT ASSY	USED ON	DO NOT SCALE DRAWING	E-mail: info@sherex.com	
			www.sherex.com	
			Phone: 866-474-3739	
			Fax: 716-875-0358	



TITLE:

CADMIUM FREE
SMALL FLANGE SWAGING

SIZE DWG. NO.

A CFT1-2520

REV

A

SCALE: 2:1 WEIGHT: kg

SHEET 1 OF 1