

REVISIONS			
REV.	DESCRIPTION	DATE	ECN
A	INITIAL RELEASE	5/20/09	1184

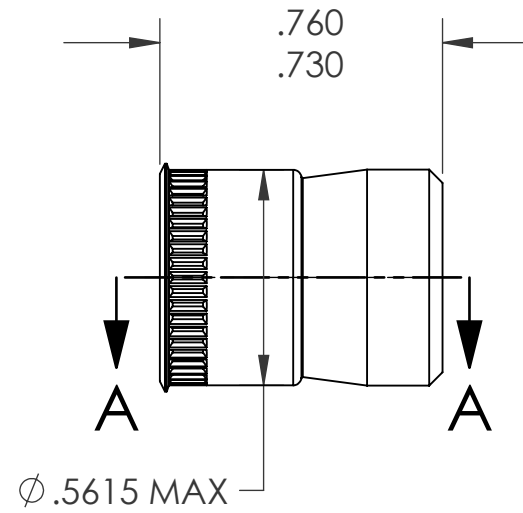

3/8-16 UNC "OVERSIZE"
NON-GAUGEABLE THREAD

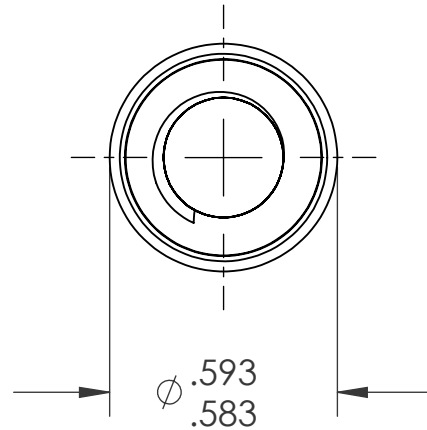
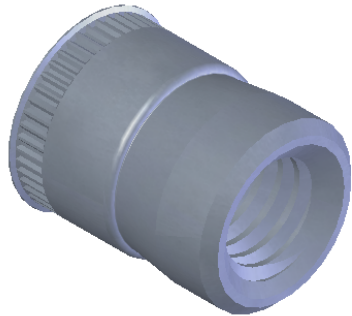
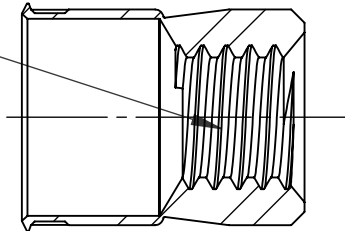

SECTION A-A

NOTE:

1. GRIP RANGE: .030 MIN.
2. HOLE SIZE:
 1. .030 - .090 MT'L THICK.: .5625 AFTER ALL APPLIED FINISHES.
 2. .091 - .124 MT'L THICK.: .5625 AFTER ALL APPLIED FINISHES.
 3. .125 - .186 MT'L THICK.: .5781 AFTER ALL APPLIED FINISHES.
 4. .187 - OVER MT'L THICK.: .5781 AFTER ALL APPLIED FINISHES.
3. INSTALLED LENGTH: N/A
4. LUBRICATION: NONE
5. INSTALLATION TOOL: SSG 803 SPIN SPIN

PROPRIETARY AND CONFIDENTIAL
THIS DRAWING, AND THE INFORMATION CONTAINED HEREIN, ARE THE PROPERTY OF SHEREX AND ARE NOT TO BE USED IN ANY MANNER DETRIMENTAL TO THE INTEREST OF THE COMPANY.
SHEREX SOLUTIONS RESERVES THE RIGHT TO REVISE PART/DRAWING WITHOUT NOTICE.

		UNLESS OTHERWISE SPECIFIED:		NAME	DATE	
		DIMENSIONS ARE IN INCHES TOLERANCES: ANGULAR: MACH ± 1 BEND ± 1 TWO PLACE DECIMAL ± .01 THREE PLACE DECIMAL ± .002		DRAWN	TWR 5/20/09	
		INTERPRET GEOMETRIC TOLERANCING PER: ASME Y14.5M-1994		CHECKED		
		MATERIAL		ENG APPR.	JVK 5/20/09	
		304L STAINLESS		MFG APPR.		
		FINISH		Q.A.	JVK 5/20/09	TITLE: CADMIUM FREE SMALL FLANGE SWAGING
NEXT ASSY		USED ON		COMMENTS:		
				E-mail: info@sherex.com www.sherex.com Phone: 866-474-3739 Fax: 716-875-0358		
APPLICATION		DO NOT SCALE DRAWING		SIZE DWG. NO.		REV
				A CFT1-3716		A
				SCALE: 2:1 WEIGHT: kg		SHEET 1 OF 1