

1/4-20 UNC "OVER SIZE"
NON-GAUGEABLE THREAD

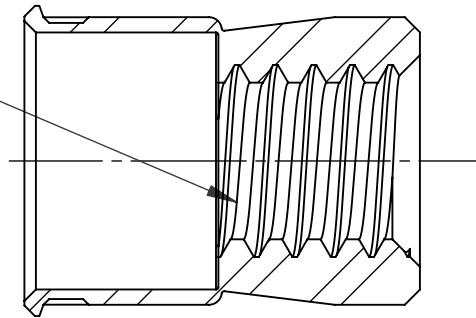

SECTION A-A

NOTE:

1. GRIP RANGE: .030 MIN.
2. HOLE SIZE:
 1. .030 - .090 MT'L THICK.: .3750 AFTER ALL APPLIED FINISHES.
 2. .091 - .124 MT'L THICK.: .3750 AFTER ALL APPLIED FINISHES.
 3. .125 - .186 MT'L THICK.: .3860 AFTER ALL APPLIED FINISHES.
 4. .187 - OVER MT'L THICK.: .3906 AFTER ALL APPLIED FINISHES.
3. INSTALLED LENGTH: N/A
4. LUBRICATION: NONE
5. INSTALLATION TOOL: SSG 802 SPIN SPIN

PROPRIETARY AND CONFIDENTIAL
THIS DRAWING, AND THE INFORMATION CONTAINED HEREIN, ARE THE PROPERTY OF SHEREX AND ARE NOT TO BE USED IN ANY MANNER DETRIMENTAL TO THE INTEREST OF THE COMPANY.
SHEREX SOLUTIONS RESERVES THE RIGHT TO REVISE PART/DRAWING WITHOUT NOTICE.

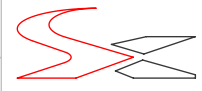
		UNLESS OTHERWISE SPECIFIED:		NAME	DATE	
		DIMENSIONS ARE IN INCHES TOLERANCES: ANGULAR: MACH ±1 BEND ±1 TWO PLACE DECIMAL ±.01 THREE PLACE DECIMAL ±.002		DRAWN	TOO	
		INTERPRET GEOMETRIC TOLERANCING PER: ASME Y14.5M-1994		CHECKED		
		MATERIAL		ENG APPR.	TOO	2/6/07
		12L14		MFG APPR.	AJP	2/6/07
		FINISH		Q.A.		
		TIN ALLOY PER ASTM B545		COMMENTS:		TITLE: CADMIUM FREE SMALL FLANGE SWAGING
NEXT ASSY	USED ON	DO NOT SCALE DRAWING		E-mail: info@sherex.com www.sherex.com Phone: 866-474-3739 Fax: 716-875-0358		
APPLICATION				SIZE DWG. NO.	REV	
				A	CFT2-2520	A
				SCALE: 2:1	WEIGHT: .0029 kg	SHEET 1 OF 1