

REVISIONS			
REV.	DESCRIPTION	DATE	ECN
A	INITIAL RELEASE	5/13/09	1182

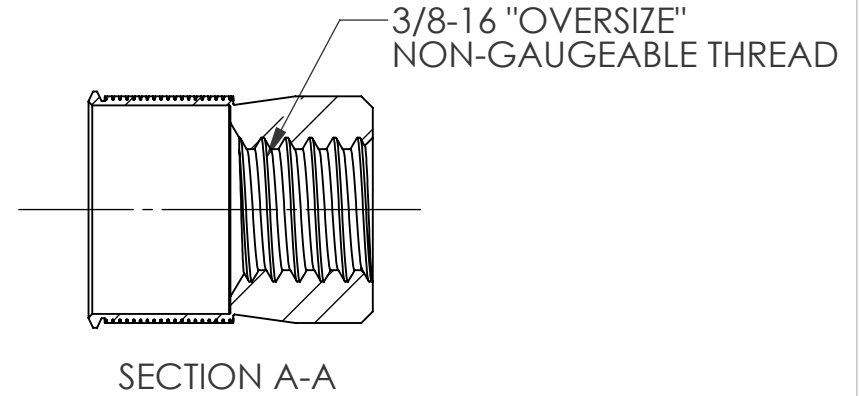
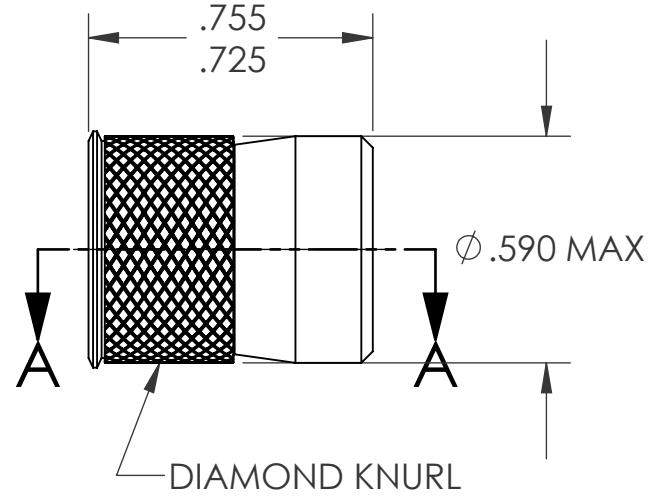
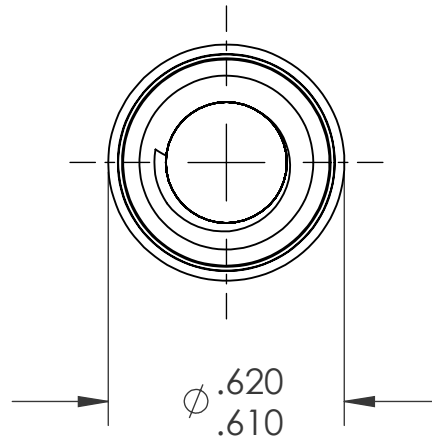
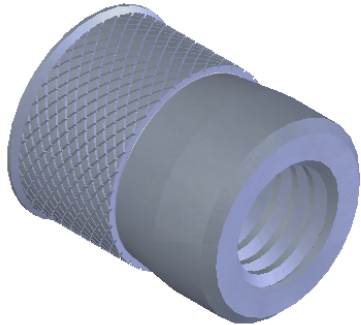
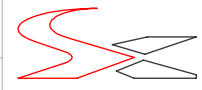

- NOTE:
- GRIP RANGE: .062 MIN.
  - HOLE SIZE: .594 +.005/-.000 AFTER ALL APPLIED FINISHES.
  - INSTALLED LENGTH: N/A
  - LUBRICATION: NONE
  - INSTALLATION TOOL: SSG 803 SPIN SPIN

**PROPRIETARY AND CONFIDENTIAL**  
 THIS DRAWING, AND THE INFORMATION CONTAINED HEREIN, ARE THE PROPERTY OF SHEREX AND ARE NOT TO BE USED IN ANY MANNER DETRIMENTAL TO THE INTEREST OF THE COMPANY.  
 SHEREX SOLUTIONS RESERVES THE RIGHT TO REVISE PART/DRAWING WITHOUT NOTICE.

		UNLESS OTHERWISE SPECIFIED:		NAME	DATE			
		DIMENSIONS ARE IN INCHES TOLERANCES: ANGULAR: MACH ±1 BEND ±1 TWO PLACE DECIMAL ±.01 THREE PLACE DECIMAL ±.002		DRAWN	TWR		5/13/09	
		INTERPRET GEOMETRIC TOLERANCING PER: ASME Y14.5M-1994		CHECKED				
		MATERIAL		ENG APPR.	JVK		5/13/09	
		304L STAINLESS		MFG APPR.				
		FINISH		Q.A.	JVK	5/13/09		
NEXT ASSY	USED ON	TIN ALLOY PER ASTM B545		COMMENTS:		<b>TITLE:</b> <b>CADMIUM FREE          KNURLED BODY SWAGING</b>		
APPLICATION		DO NOT SCALE DRAWING		E-mail: info@sherex.com www.sherex.com Phone: 866-474-3739 Fax: 716-875-0358			<b>SIZE DWG. NO.</b> <b>A CFW1-3716</b>	<b>REV</b> <b>A</b>
							<b>SCALE: 2:1</b>	<b>WEIGHT: .0101 kg</b>