

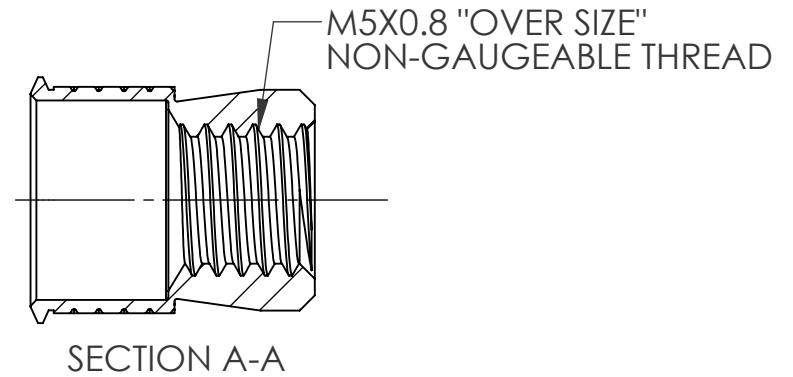

REVISIONS			
REV.	DESCRIPTION	DATE	ECN
A	INITIAL RELEASE	5/11/09	1182

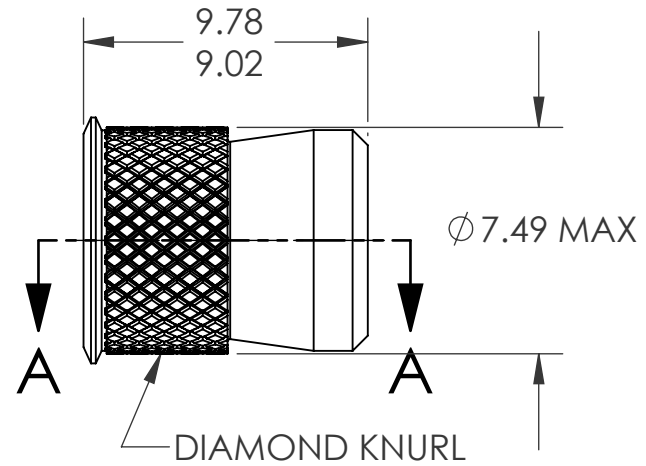
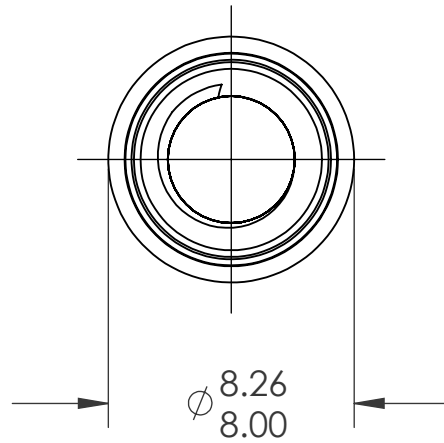
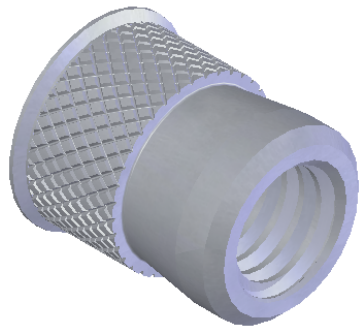

**NOTE:**

- GRIP RANGE: 1.57 MIN.
- HOLE SIZE: 7.54 + 0.13/-0.0 AFTER ALL APPLIED FINISHES.
- INSTALLED LENGTH: N/A
- LUBRICATION: NONE
- INSTALLATION TOOL: SSG 802 SPIN SPIN

**PROPRIETARY AND CONFIDENTIAL**  
 THIS DRAWING, AND THE INFORMATION CONTAINED HEREIN, ARE THE PROPERTY OF SHEREX AND ARE NOT TO BE USED IN ANY MANNER DETRIMENTAL TO THE INTEREST OF THE COMPANY.  
 SHEREX SOLUTIONS RESERVES THE RIGHT TO REVISE PART/DRAWING WITHOUT NOTICE.

		UNLESS OTHERWISE SPECIFIED:		NAME	DATE			
		DIMENSIONS ARE IN MILLIMETERS TOLERANCES: ANGULAR: MACH ± 1 BEND ± 1 ONE PLACE DECIMAL ± 0.10 TWO PLACE DECIMAL ± 0.05		DRAWN	TWR		5/11/09	
		INTERPRET GEOMETRIC TOLERANCING PER: ASME Y14.5M-1994		CHECKED				
		MATERIAL		ENG APPR.	JVK		5/11/09	
		304L STAINLESS		MFG APPR.				
		FINISH		Q.A.	JVK	5/11/09		
		TIN ALLOY PER ASTM B545		COMMENTS:		<b>TITLE:</b> <b>CADMIUM FREE          KNURLED BODY SWAGING</b>		
NEXT ASSY	USED ON			E-mail: info@sherex.com www.sherex.com Phone: 866-474-3739 Fax: 716-875-0358			<b>SIZE DWG. NO.</b> <b>A CFW1-580</b>	<b>REV</b> <b>A</b>
APPLICATION		DO NOT SCALE DRAWING					<b>SCALE: 2:1</b>	<b>WEIGHT: .0013 kg</b>