

REVISIONS			
REV.	DESCRIPTION	DATE	ECN
A	INITIAL RELEASE	5/12/09	1182

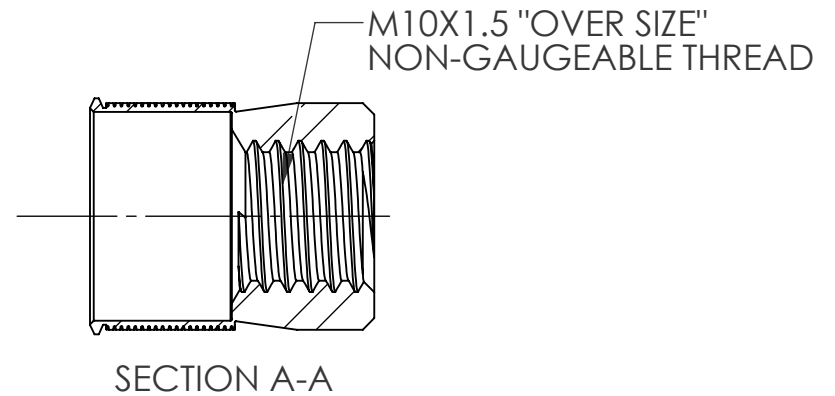
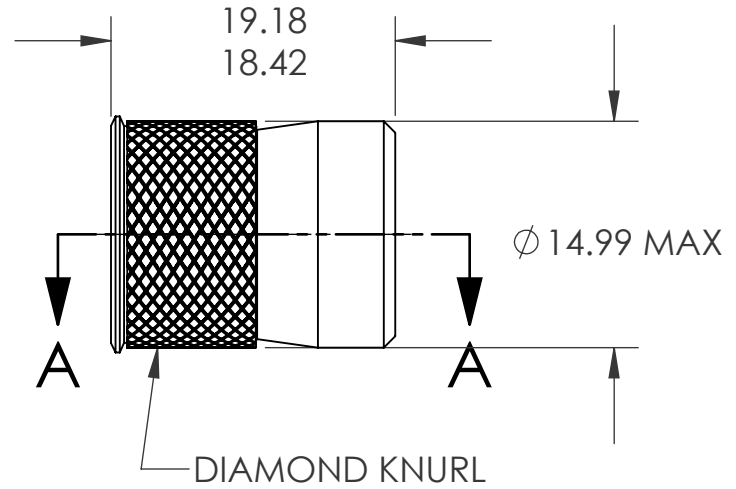
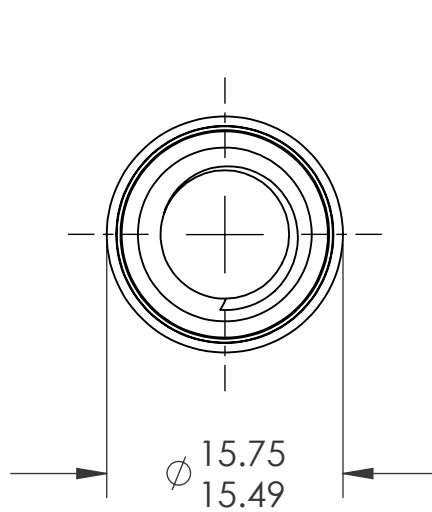
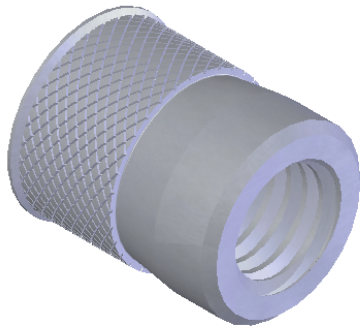

NOTE:

- GRIP RANGE: 1.57 MIN.
- HOLE SIZE: 15.00 +0.13/-0.0 AFTER ALL APPLIED FINISHES.
- INSTALLED LENGTH: N/A
- LUBRICATION: NONE
- INSTALLATION TOOL: SSG 803 SPIN SPIN

PROPRIETARY AND CONFIDENTIAL

THIS DRAWING, AND THE INFORMATION CONTAINED HEREIN, ARE THE PROPERTY OF SHEREX AND ARE NOT TO BE USED IN ANY MANNER DETRIMENTAL TO THE INTEREST OF THE COMPANY.
SHEREX SOLUTIONS RESERVES THE RIGHT TO REVISE PART/DRAWING WITHOUT NOTICE.

		UNLESS OTHERWISE SPECIFIED:	NAME	DATE
		DIMENSIONS ARE IN INCHES TOLERANCES: ANGULAR: MACH \pm 1 BEND \pm 1 TWO PLACE DECIMAL \pm .01 THREE PLACE DECIMAL \pm .002	DRAWN	TWR 5/12/09
		INTERPRET GEOMETRIC TOLERANCING PER: ASME Y14.5M-1994	CHECKED	
		MATERIAL	ENG APPR.	JVK 5/12/09
		6061-T6 ALUMINUM	MFG APPR.	
		FINISH	Q.A.	JVK 5/12/09
		TIN ALLOY PER ASTM B545	COMMENTS:	
NEXT ASSY	USED ON		E-mail: info@sherex.com	
			www.sherex.com	
			Phone: 866-474-3739	
			Fax: 716-875-0358	
APPLICATION		DO NOT SCALE DRAWING		

TITLE:		
CADMIUM FREE KNURLED BODY SWAGING		
SIZE	DWG. NO.	REV
A	CFW3-1015	A
SCALE: 2:1	WEIGHT: .0096 kg	SHEET 1 OF 1