

REVISIONS			
REV.	DESCRIPTION	DATE	ECN
A	INITIAL RELEASE	10/7/08	
B	NEW FINISH PER SFS-01-001, SC2	3/9/15	1797

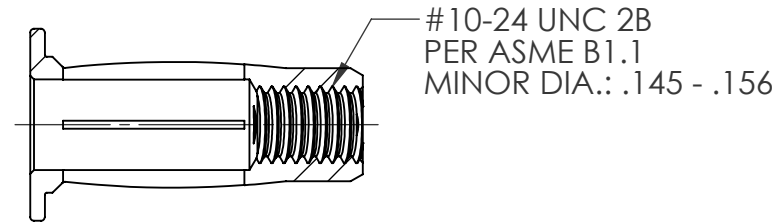

SECTION A-A

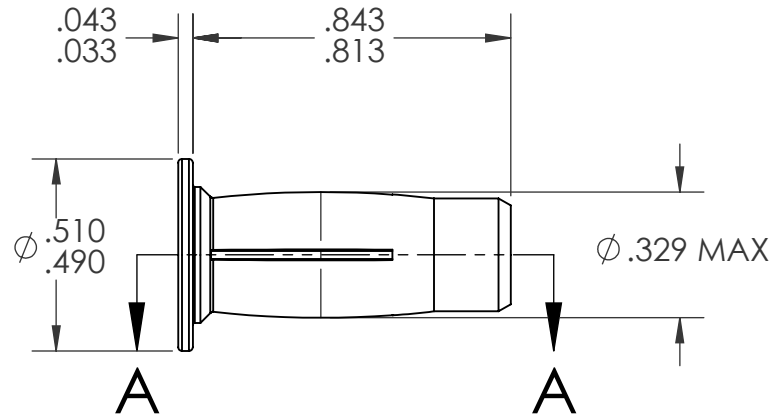
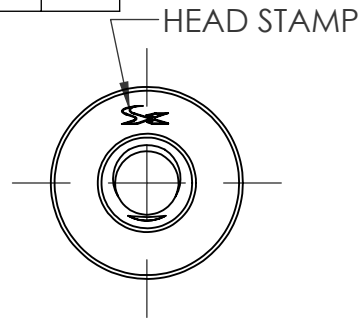

NOTE:

- GRIP RANGE: .020 - .175
- HOLE SIZE: .336 +.006/-.000 AFTER ALL APPLIED FINISHES.
- INSTALLED LENGTH: .410 REF.
- LUBRICATION: WAX
- INSTALLATION TOOL: SSG 802 SPIN SPIN

PROPRIETARY AND CONFIDENTIAL
 THIS DRAWING, AND THE INFORMATION CONTAINED HEREIN, ARE THE PROPERTY OF SHEREX AND ARE NOT TO BE USED IN ANY MANNER DETRIMENTAL TO THE INTEREST OF THE COMPANY.
 SHEREX RESERVES THE RIGHT TO REVISE PART/DRAWING WITHOUT NOTICE.

		UNLESS OTHERWISE SPECIFIED: DIMENSIONS ARE IN INCHES TOLERANCES: ANGULAR: MACH ±1 BEND ±1 TWO PLACE DECIMAL ±.01 THREE PLACE DECIMAL ±.005 INTERPRET GEOMETRIC TOLERANCING PER: ASME Y14.5M-1994 MATERIAL C1008/C1010 FINISH ZINC PLATE W/YELLOW TRIVALENT CHROMATE PER SFS-01-001, SC2			NAME TOO CHECKED TOO MFG APPR. AJP Q.A.	DATE 7/20/05 7/20/05 7/20/05
NEXT ASSY	USED ON				COMMENTS: E-mail: info@sherex.com www.sherex.com Phone: 866-474-3739 Fax: 716-875-0358	
APPLICATION		DO NOT SCALE DRAWING				



TITLE:
PRE-BULBED SLOTTED BODY

SIZE A	DWG. NO. CPB2-1024-175	REV B
------------------	---------------------------	----------

SCALE: 2:1 WEIGHT: .0047 kg SHEET 1 OF 1