

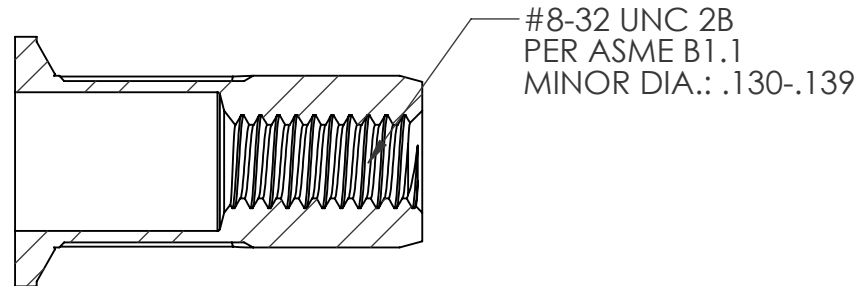

REVISIONS				
REV.	DESCRIPTION	DATE	ECN	INITIALS
A	INITIAL RELEASE	10/7/2020	3692	TDJ
B	UPDATE BODY DIAMETER	09/07/22	4105	MRA

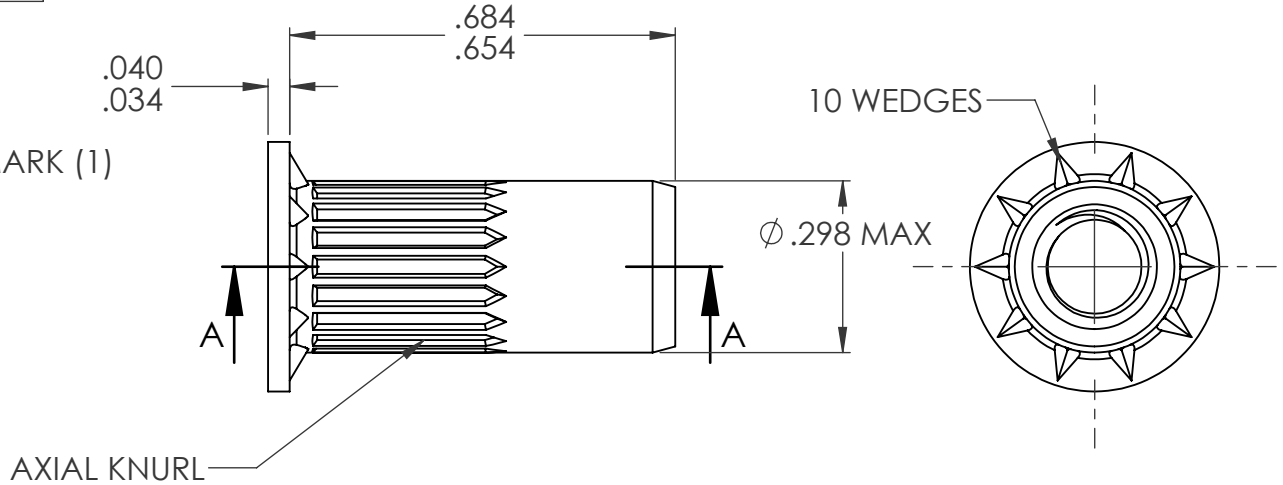
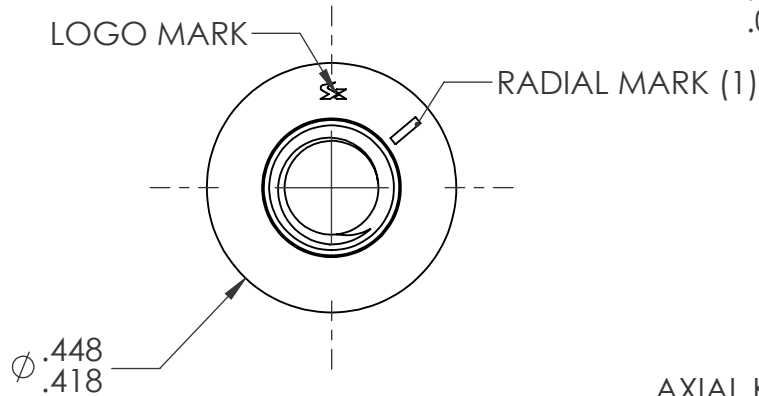

SECTION A-A

NOTE:

- GRIP RANGE: .118-.217
- HOLE SIZE: .300 +.006/-.000 AFTER ALL APPLIED FINISHES.
- INSTALLED LENGTH: .413 MAX.
- LUBRICATION: NONE
- INSTALLATION TOOL: SPIN PULL

CUSTOMER APPROVAL: DATE:		UNLESS OTHERWISE SPECIFIED: DIMENSIONS ARE IN INCHES TOLERANCES: ANGULAR: MACH ± 1 BEND ± 1 TWO PLACE DECIMAL ± .01 THREE PLACE DECIMAL ± .005 INTERPRET GEOMETRIC TOLERANCING PER: ASME Y14.5M-1994		NAME	DATE		
				DRAWN	TDJ		10/7/2020
PROPRIETARY AND CONFIDENTIAL <small>THIS DRAWING, AND THE INFORMATION CONTAINED HEREIN, ARE THE PROPERTY OF SHEREX AND ARE NOT TO BE USED IN ANY MANNER DETRIMENT TO THE INTEREST OF THE COMPANY. SHEREX SOLUTIONS RESERVES THE RIGHT TO REVISE PART/DRAWING WITHOUT NOTICE. UNLESS OTHERWISE SPECIFIED, ALL SPECIFICATIONS REFERENCED ON THIS DRAWING WILL PERTAIN TO THE MOST RECENT AND ACTIVE REVISION.</small>		MATERIAL C1008/C1010		ENG APPR.	JVK	10/7/2020	TITLE: #8-32 OPEN END LARGE FLANGE OPTISERT
				MFG APPR.		Q.A.	
NEXT ASSY USED ON APPLICATION		FINISH ZINC PLATE CLEAR TRIVALENT CHROMATE PER SFS-01-001; SC1 DO NOT SCALE DRAWING		COMMENTS:		SIZE DWG. NO.	REV
				E-mail: info@sherex.com www.sherex.com Phone: 866-474-3739 Fax: 716-875-0358		A OPT2-0832-217	B
				SCALE: 3:1 WEIGHT:		SHEET 1 OF 1	