

REVISIONS				
REV.	DESCRIPTION	DATE	ECN	INITIAL
A	INITIAL RELEASE	03/05/21	3794	FCG

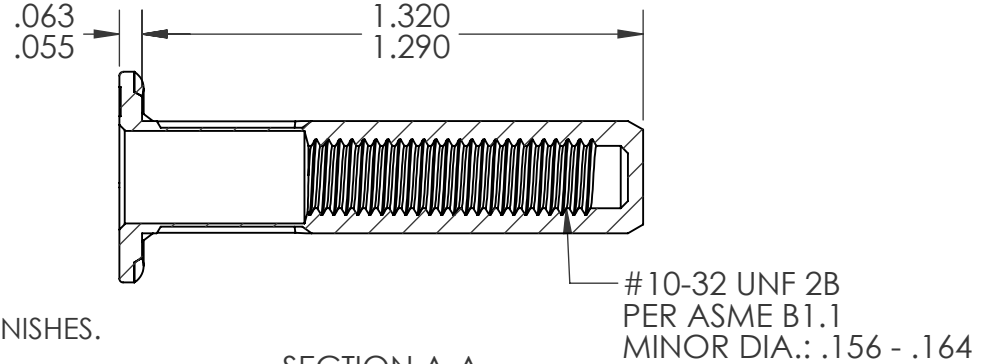
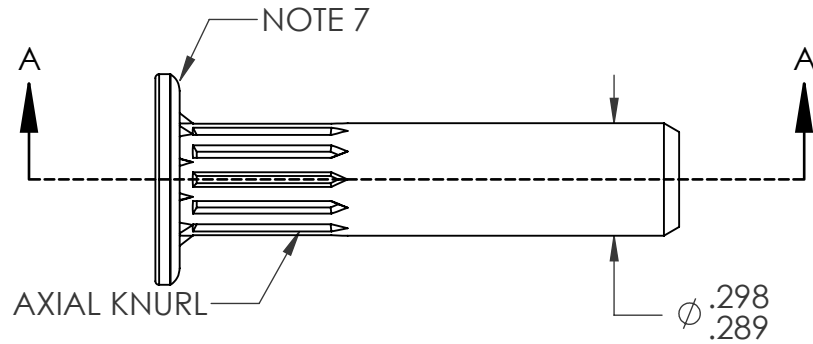
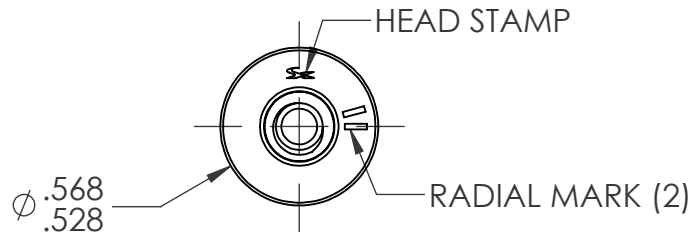

NOTE:

1. GRIP RANGE: .217 - .315
2. HOLE SIZE: .300 +.006/-.000 AFTER ALL APPLIED FINISHES.
3. INSTALLED LENGTH: 0.951 MAX.
4. INSTALLED THREAD DEPTH: .984 MIN. IN MIN. GRIP
5. LUBRICATION: WAX
6. INSTALLATION TOOL: SPIN-PULL
7. DEPOSIT PLASTISOL ALONG OUTER GROOVE OF THE HEAD. SEAL MUST NOT CONTACT WEDGES.

PROPRIETARY AND CONFIDENTIAL

THIS DRAWING, AND THE INFORMATION CONTAINED HEREIN, ARE THE PROPERTY OF SHEREX AND ARE NOT TO BE USED IN ANY MANNER DETRIMENTAL TO THE INTEREST OF THE COMPANY.
SHEREX SOLUTIONS RESERVES THE RIGHT TO REVISE PART/DRAWING WITHOUT NOTICE.

		UNLESS OTHERWISE SPECIFIED:	NAME	DATE
		DIMENSIONS ARE IN INCHES TOLERANCES: ANGULAR: MACH ± 1 BEND ± 1 TWO PLACE DECIMAL $\pm .01$ THREE PLACE DECIMAL $\pm .002$	DRAWN	FCG 03/05/21
		INTERPRET GEOMETRIC TOLERANCING PER: ASME Y14.5M-1994	CHECKED	
		MATERIAL	ENG APPR.	CL 03/05/21
		C1008/C1010	MFG APPR.	
		FINISH	Q.A.	
		ZINC PLATE CLEAR TRIVALENT CHROMATE PER SFS-01-001, SC1	COMMENTS:	
NEXT ASSY	USED ON		E-mail: info@sherex.com	
			www.sherex.com	
			Phone: 866-474-3739	
			Fax: 716-875-0358	
APPLICATION		DO NOT SCALE DRAWING		

		
SIZE DWG. NO.	REV	
A OPT2-1032-315BS	A	
SCALE: 2:1	WEIGHT:	SHEET 1 OF 1