

REVISIONS					
REV.	DESCRIPTION	DATE	ECN	INITIAL	
A	INITIAL RELEASE	7/31/2020	3657	ARG	

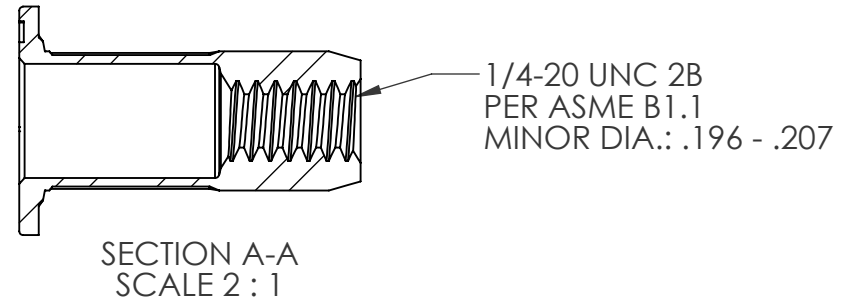
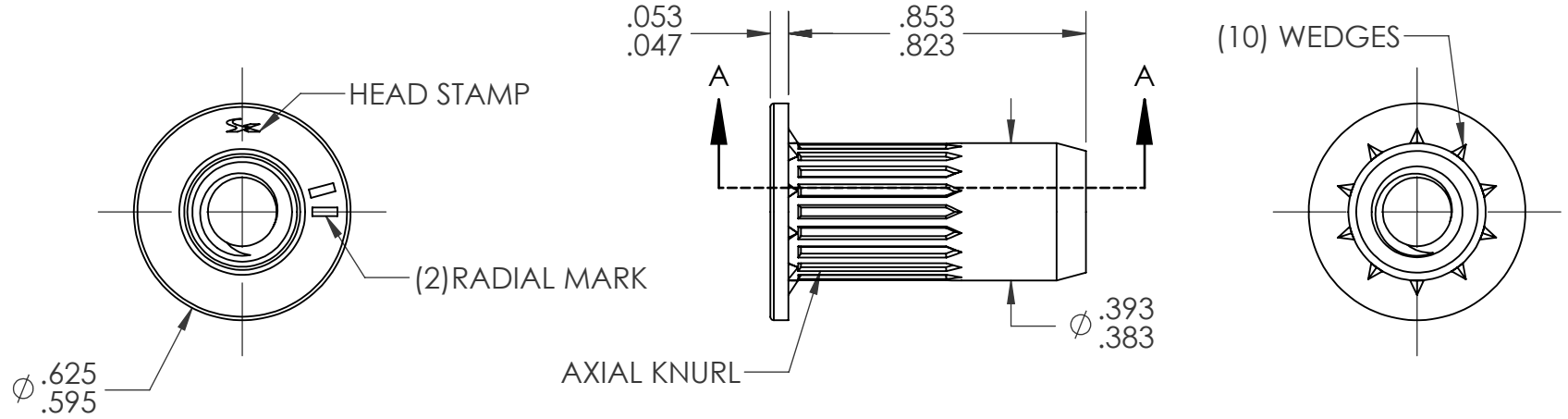

NOTE:

- GRIP RANGE: .236 - .335
- HOLE SIZE: $.394 +.006/-0.00$ AFTER ALL APPLIED FINISHES.
- INSTALLED LENGTH: .433 MAX
- LUBRICATION: NONE
- INSTALLATION TOOL: SPIN-PULL
- THREADS MEET GRADE 5 PROOF LOAD: 4250lbf PER SAE J995

PROPRIETARY AND CONFIDENTIAL
 THIS DRAWING, AND THE INFORMATION CONTAINED HEREIN, ARE THE PROPERTY OF SHEREX AND ARE NOT TO BE USED IN ANY MANNER DETRIMENTAL TO THE INTEREST OF THE COMPANY.
 SHEREX SOLUTIONS RESERVES THE RIGHT TO REVISE PART/DRAWING WITHOUT NOTICE.

		UNLESS OTHERWISE SPECIFIED:	NAME	DATE	
		DIMENSIONS ARE IN MILLIMETERS TOLERANCES: ANGULAR: MACH ± 1 BEND ± 1 ONE PLACE DECIMAL ± 0.3 TWO PLACE DECIMAL ± 0.08	DRAWN	ARG	
		INTERPRET GEOMETRIC TOLERANCING PER: ASME Y14.5M-1994	CHECKED		
		MATERIAL C1008/C1010	ENG APPR.		
		FINISH ZINC PLATE CLEAR TRIVALENT CHROMATE PER SFS-01-001, SC1	MFG APPR.		
NEXT ASSY	USED ON		Q.A.		
APPLICATION		DO NOT SCALE DRAWING	COMMENTS: E-mail: info@sherex.com www.sherex.com Phone: 866-474-3739 Fax: 716-875-0358		TITLE: 1/4 - 20 OPEN END LARGE FLANGE OPTISERT
			SIZE DWG. NO.	REV	
			A OPT2-2520-335	A	
			SCALE: 2:1	WEIGHT:	SHEET 1 OF 1