

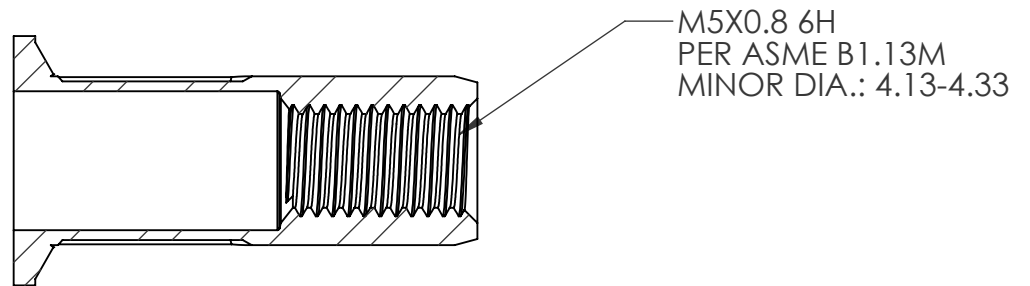

REVISIONS				
REV.	DESCRIPTION	DATE	ECN	INITIALS
A	INITIAL RELEASE	10/7/2020	3692	TDJ

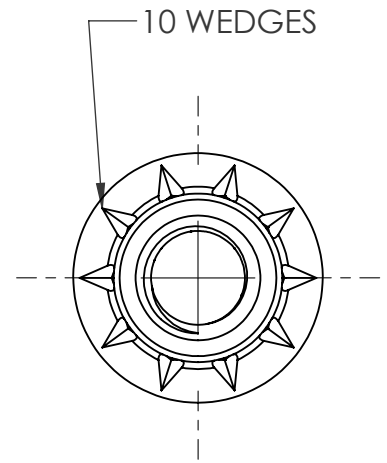
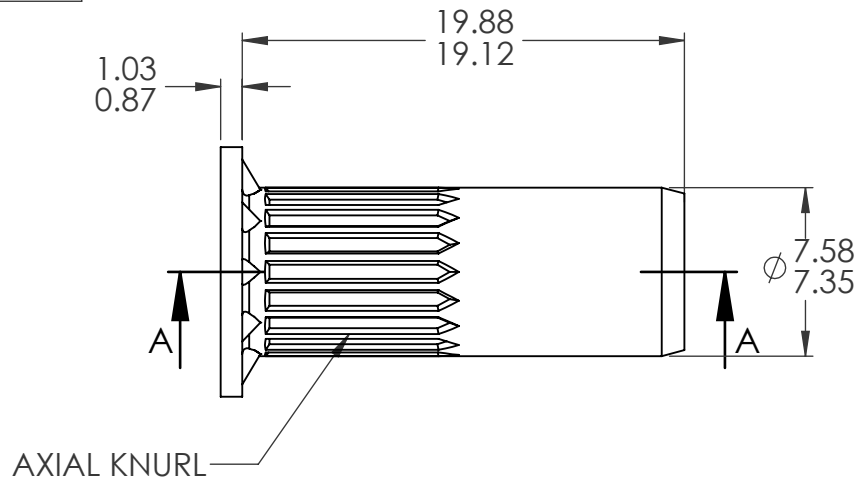
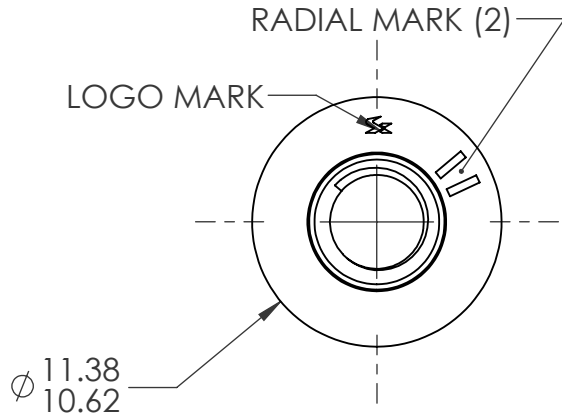

SECTION A-A

NOTE:

- GRIP RANGE: 5.5 - 8.0
- HOLE SIZE: 7.60 +0.15-0.00 AFTER ALL APPLIED FINISHES.
- INSTALLED LENGTH: 10.5 MAX.
- LUBRICATION: NONE
- INSTALLATION TOOL: SPIN PULL

CUSTOMER APPROVAL:				UNLESS OTHERWISE SPECIFIED:				NAME		DATE					
DATE:				DIMENSIONS ARE IN MILLIMETERS TOLERANCES: ANGULAR: MACH ± 1 BEND ± 1 ONE PLACE DECIMAL ± 0.3 TWO PLACE DECIMAL ± 0.08		DRAWN		TDJ		10/7/2020				TITLE: M5 OPEN END LARGE FLANGE OPTISERT	
				INTERPRET GEOMETRIC TOLERANCING PER: ASME Y14.5M-1994		CHECKED		CL		10/7/2020					
				MATERIAL C1008/C1010		ENG APPR.		JVK		10/7/2020		SCALE: 3:1 WEIGHT: SHEET 1 OF 1			
				FINISH ZINC PLATE CLEAR TRIVALENT CHROMATE PER SFS-01-001; SC1		MFG APPR.									
				APPLICATION		DO NOT SCALE DRAWING		Q.A.							
								COMMENTS:							
								E-mail: info@sherex.com							
								www.sherex.com							
								Phone: 866-474-3739							
								Fax: 716-875-0358							