

REVISIONS				
REV.	DESCRIPTION	DATE	ECN	INITIAL
A	INITIAL RELEASE	7/31/2020	3657	ARG

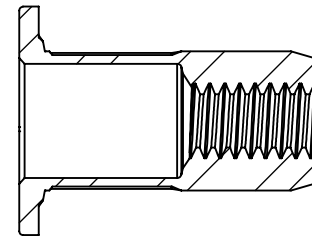
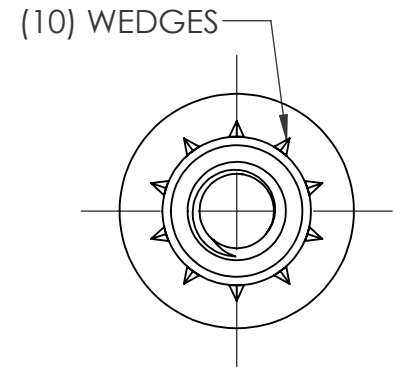
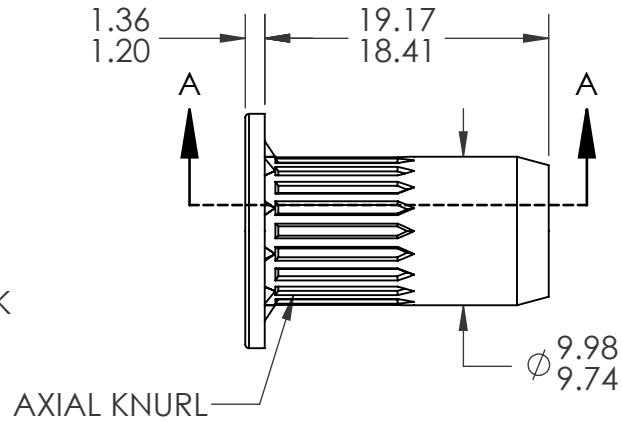
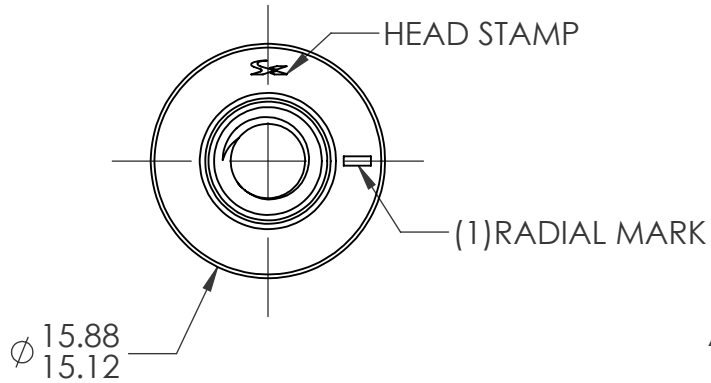

M6X1.0 6H  
PER ASME B1.13M  
MINOR DIA.: 4.92 - 5.15

SECTION A-A  
SCALE 2 : 1

NOTE:

- GRIP RANGE: 3.5 - 6.0
- HOLE SIZE: 10.00 +0.15/-0.00 AFTER ALL APPLIED FINISHES.
- INSTALLED LENGTH: 11.0 MAX
- LUBRICATION: NONE
- INSTALLATION TOOL: SPIN-PULL
- THREADS MEET CLASS 8 PROOF LOAD: 17.2kN PER ISO 898-2

**PROPRIETARY AND CONFIDENTIAL**

THIS DRAWING, AND THE INFORMATION CONTAINED HEREIN, ARE THE PROPERTY OF SHEREX AND ARE NOT TO BE USED IN ANY MANNER DETRIMENTAL TO THE INTEREST OF THE COMPANY.  
SHEREX SOLUTIONS RESERVES THE RIGHT TO REVISE PART/DRAWING WITHOUT NOTICE.

		UNLESS OTHERWISE SPECIFIED:	NAME	DATE
		DIMENSIONS ARE IN MILLIMETERS TOLERANCES: ANGULAR: MACH ± 1 BEND ± 1 ONE PLACE DECIMAL ± 0.3 TWO PLACE DECIMAL ± 0.08	DRAWN	ARG 7/31/20
		INTERPRET GEOMETRIC TOLERANCING PER: ASME Y14.5M-1994	CHECKED	
		MATERIAL C1008/C1010	ENG APPR.	
		FINISH ZINC PLATE CLEAR TRIVALENT CHROMATE PER SFS-01-001, SC1	MFG APPR.	
NEXT ASSY	USED ON		Q.A.	
APPLICATION		DO NOT SCALE DRAWING	COMMENTS: E-mail: info@sherex.com www.sherex.com Phone: 866-474-3739 Fax: 716-875-0358	

		TITLE:	
		M6 OPEN END LARGE FLANGE OPTISERT	
SIZE DWG. NO.	REV		
<b>A</b> OPT2-610-6.0	A		
SCALE: 2:1	WEIGHT:	SHEET 1 OF 1	