

REVISIONS			
REV.	DESCRIPTION	DATE	ECN
A	INITIAL RELEASE	4/3/09	1160

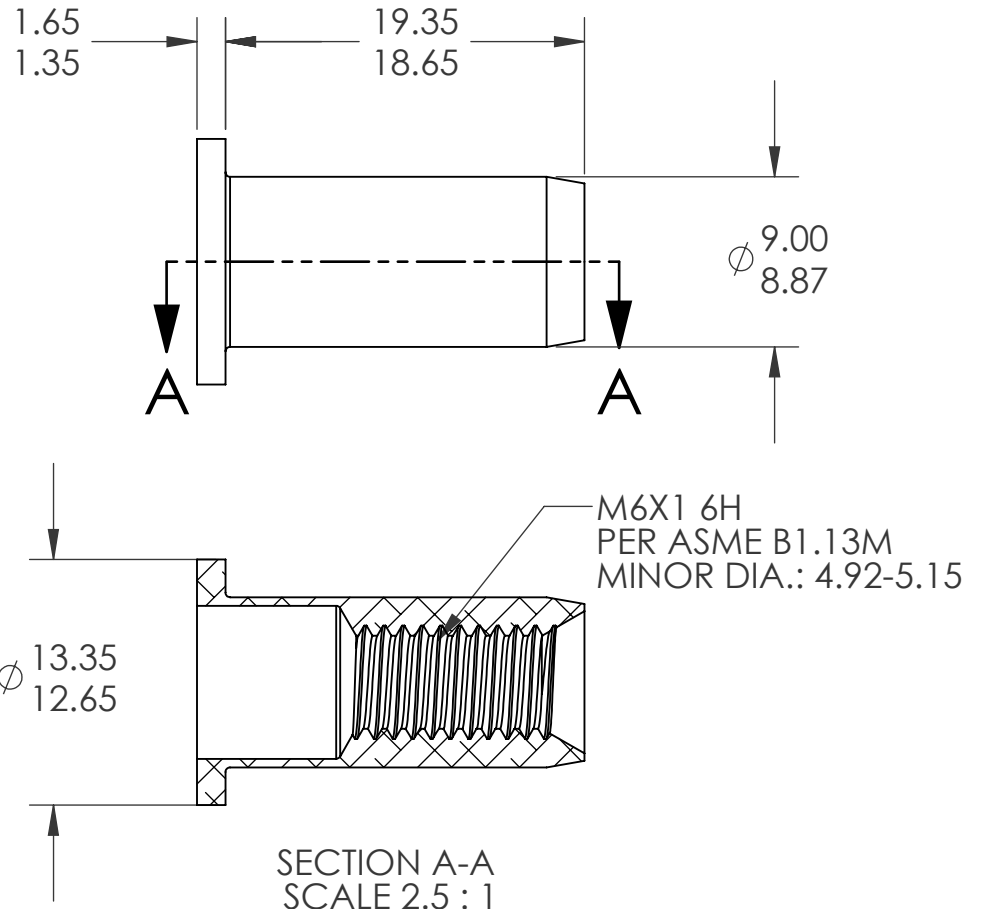
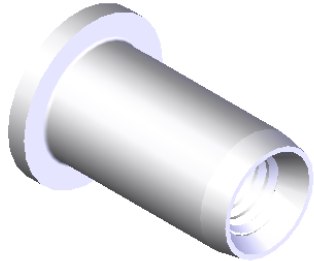
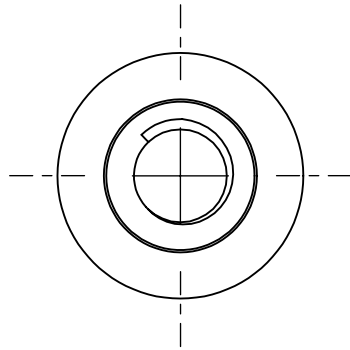

NOTE:

- GRIP RANGE: 5.5 - 8.0
- HOLE SIZE: 9.0 +0.1/-0.0 AFTER ALL APPLIED FINISHES.
- INSTALLED LENGTH: N/A
- INSTALLED THREAD DEPTH:
- LUBRICATION: NONE
- INSTALLATION TOOL: MS 50 SPIN PULL

PROPRIETARY AND CONFIDENTIAL
THIS DRAWING, AND THE INFORMATION CONTAINED HEREIN, ARE THE PROPERTY OF SHEREX AND ARE NOT TO BE USED IN ANY MANNER DETRIMENTAL TO THE INTEREST OF THE COMPANY.
SHEREX SOLUTIONS RESERVES THE RIGHT TO REVISE PART/DRAWING WITHOUT NOTICE.

		UNLESS OTHERWISE SPECIFIED:	NAME	DATE
		DIMENSIONS ARE IN MILLIMETERS TOLERANCES: ANGULAR: MACH ± 1 BEND ± 1 ONE PLACE DECIMAL ± 0.10 TWO PLACE DECIMAL ± 0.05	DRAWN	TWR 4/3/09
		INTERPRET GEOMETRIC TOLERANCING PER: ASME Y14.5M-1994	CHECKED	
		MATERIAL ALUMINUM ALMG 2.5 DIN 3.3523	ENG APPR.	JVK 4/3/09
		FINISH NONE	MFG APPR.	
NEXT ASSY	USED ON		Q.A.	JVK 4/3/09
APPLICATION		DO NOT SCALE DRAWING	COMMENTS: E-mail: info@sherex.com www.sherex.com Phone: 866-474-3739 Fax: 716-875-0358	

		
TITLE: FLAT HEAD OPEN END		
SIZE DWG. NO.	REV	
A TU-AM6UPO80	A	
SCALE: 2:1	WEIGHT: .0017 kg	SHEET 1 OF 1