

| REVISIONS | | | |
|-----------|-----------------|----------|------|
| REV. | DESCRIPTION | DATE | ECN |
| A | INITIAL RELEASE | 2/7/2014 | 1657 |

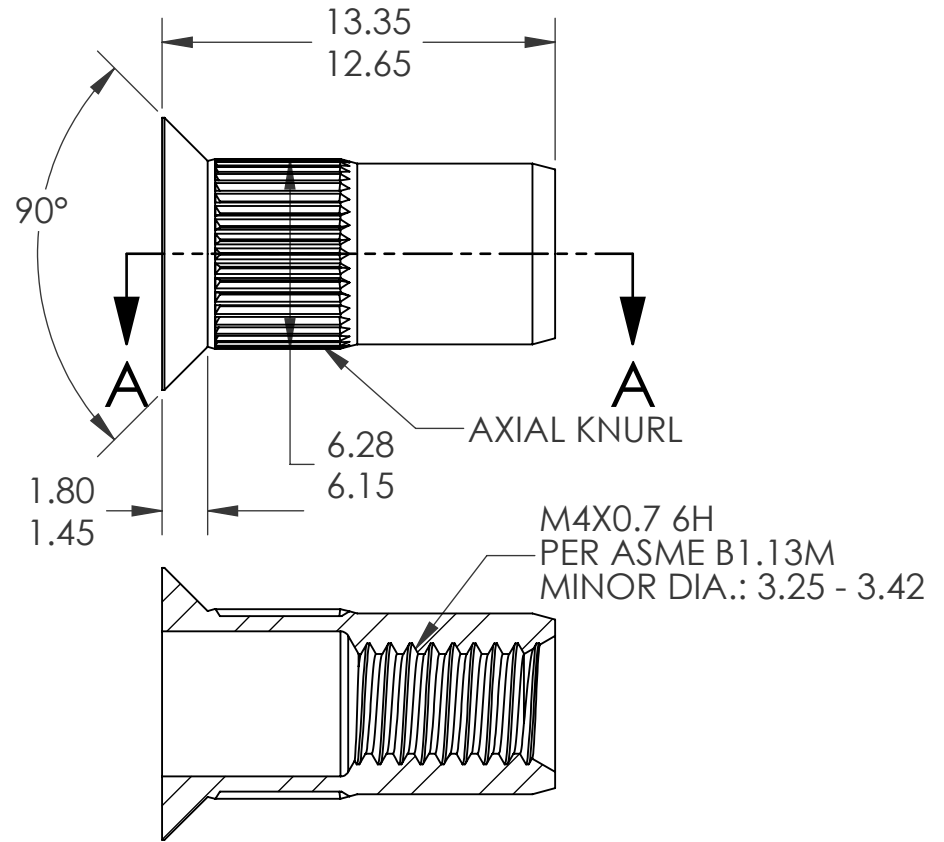
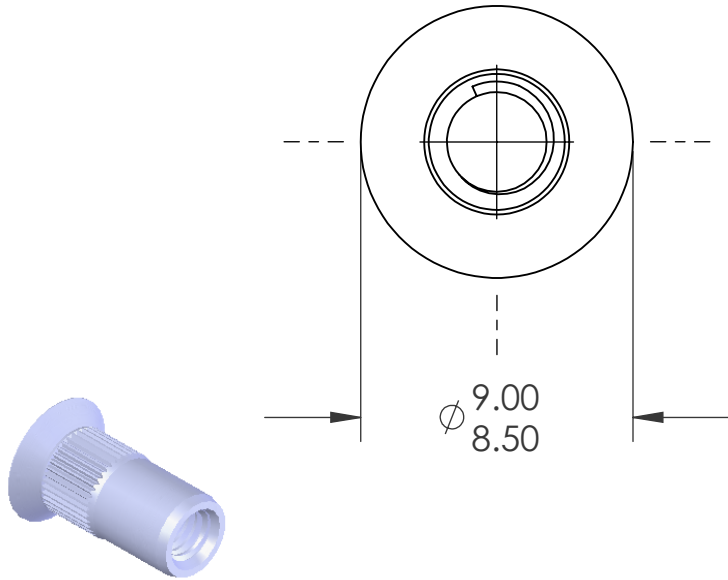

SECTION A-A

NOTE:

- GRIP RANGE: 3.5 - 5.0
- HOLE SIZE: 6.4 +0.1/-0.0 AFTER ALL APPLIED FINISHES.
- INSTALLED LENGTH: N/A
- INSTALLED THREAD DEPTH:
- LUBRICATION: NONE
- INSTALLATION TOOL: FLEX 5P/5S SPIN PULL

PROPRIETARY AND CONFIDENTIAL

THIS DRAWING, AND THE INFORMATION CONTAINED HEREIN, ARE THE PROPERTY OF SHEREX AND ARE NOT TO BE USED IN ANY MANNER DETRIMENTAL TO THE INTEREST OF THE COMPANY.
SHEREX SOLUTIONS RESERVES THE RIGHT TO REVISE PART/DRAWING WITHOUT NOTICE.

| | | | | | |
|-------------|---------|--|-------------------------|------|----------|
| | | UNLESS OTHERWISE SPECIFIED: | | NAME | DATE |
| | | DIMENSIONS ARE IN MILLIMETERS TOLERANCES: ANGULAR: MACH ± 1 BEND ± 1 ONE PLACE DECIMAL ± 0.10 TWO PLACE DECIMAL ± 0.05 | DRAWN | JMC | 2/7/2014 |
| | | INTERPRET GEOMETRIC TOLERANCING PER: ASME Y14.5M-1994 | CHECKED | | |
| | | MATERIAL | ENG APPR. | JVK | 2/7/2014 |
| | | STEEL DIN QST 34-3 | MFG APPR. | | |
| | | FINISH | Q.A. | JR | 2/7/2014 |
| | | ZINKTOP CLEAR, ROHS COMPLIANT 96W/480R | COMMENTS: | | |
| NEXT ASSY | USED ON | | E-mail: info@sherex.com | | |
| | | | www.sherex.com | | |
| | | | Phone: 866-474-3739 | | |
| | | | Fax: 716-875-0358 | | |
| APPLICATION | | DO NOT SCALE DRAWING | | | |



TITLE:

COUNTERSUNK HEAD RIBBED SHANK

SIZE DWG. NO.

A TU-SM4UFO50RZT

REV

A

SCALE: 2:1 WEIGHT: .0015 kg

SHEET 1 OF 1